



INSTALLATION MANUAL

CERV2-8EC



Build Equinox
support@buildequinox.com
(773)-492-1893

Rev 3.1 - 03/07/2024

© Build Equinox 2024

Contents

Specifications.....	3
General Considerations	6
Installation Procedure	7
Unit Installation & Ducting	7
Insulating.....	7
Ducting Example #1:	8
Ducting Example #2:	9
Ducting Example #3:	10
Ducting Example #4:	11
Water Drain	12
Overflow Pan.....	12
Wet Switch.....	13
Electrical.....	15
General Wiring Guidelines.....	15
Electrical Installation	15
Regular Maintenance	16
Filters.....	16
Starting and Commissioning the System	18
Touch Screen Interface	18
ECM Fan Speed Configuration	18
Appendix – Wi-Fi Setup	19
Appendix – Wi-Fi Setup Alternative: Computer or Mobile Device	21
Appendix - CERV-ICE Online Control & Monitoring Account Setup.....	23
Appendix – Fan Speed Configuration.....	25
Appendix - Electrical.....	26
CERV Internal Wiring Diagram	26
Front Panel Removal and Auxiliary Input/Output (X0 and I0) Access	27
Built-In Auxiliary Input and Output (X0 and I0).....	29
Wired Auxiliary Output Example – Inline Duct Heater (wiring).....	30
Wired Auxiliary Output Example – Inline Duct Heater (Configuration).....	31
Wired Auxiliary Output Example – Fan Interlock (wiring).....	32
Wired Auxiliary Output Example – Fan Interlock (Configuration)	33

Specifications

Electrical

Voltage Supply	120V (60hz)
Min Circuit Size	12 A
Connection	NEMA 15-5P Plug, 6ft cord

System

Unit Dimensions	25.5" W x 40" L x 38" H
Unit Weight	142lbs (8EC)
Airflow Rate	100-300 CFM
Air Filter Size	10" x 20" x (1" or 2")
Duct Size	8" Round
Condensate Drain	3/4" PVC Male

Sensors

Temperature	-40 to 185F +/- 0.36F
Relative Humidity	0 to 100% +/- 2%
CO ₂	0 to 5000ppm +/- 25ppm +/- 3%
VOC	450 to 2000ppm CO ₂ Equivalent

VOCs Detected

Alcohols, Aldehydes, Aliphatic Hydrocarbons, Amines, Aromatic Hydrocarbons, CO, CH₄, LPG, Ketones, Organic Acids

Sensors are self-calibrating and do not require maintenance

Warranty

Parts and Labor	1 st Year
Parts	5 Years

ECM Fan Efficiency

Airflow @100pa (0.4"wg) ESP	200CFM
Total Fan Power ECM Fans (Heating and Cooling)	36.8W (50% Speed) 98.1W (70% Speed)
Single Fan Efficiency System Includes 2 Fans	0.25 W/CFM 4 CFM/W

Performance

Heating: 47F Outside, 68F Inside

Heating Capacity (Btu/h)	4731 (recirc)* 6531 (vent)**
Heating Efficiency (COP) (excludes fan power - see above)	3.6 (recirc) 4.8 (vent)
Heating Elec Power (W) (excludes fan power - see above)	379 (recirc) 399 (vent)

Heating: 32F Outside, 68F Inside

Heating Capacity (Btu/h)	3702 (recirc) 6789 (vent)
Heating Efficiency (COP) (excludes fan power - see above)	3.3 (recirc) 5.4 (vent)
Heating Elec Power (W) (excludes fan power - see above)	331 (recirc) 366 (vent)

Heating: 17F Outside, 68F Inside

Heating Capacity (Btu/h)	2674 (recirc) 7046 (vent)
Heating Efficiency (COP) (excludes fan power - see above)	2.8 (recirc) 6.2 (vent)
Heating Elec Power (W) (excludes fan power - see above)	283 (recirc) 332 (vent)

Cooling: 95F(DB)/75F(WB) Outside, 80F(DB)/67F(WB) Inside

Cooling capacity (Btu/h)	2230 (recirc) 5314 (vent)
Sensible cooling (Btu/h)	1318 (recirc) 3891 (vent)
Latent cooling (Btu/h)	912 (recirc) 1423 (vent)
Dehumidification (Liters/day)	9.6 (recirc) 14.9 (vent)
Cooling Efficiency (COP) (excludes fan power - see above)	3.2 (recirc) 7.6 (vent)
Cooling Elec Power (W) (excludes fan power - see above)	202 (recirc) 204 (vent)

* Recirculation mode heating and cooling capacity is relative to indoor conditions

** Ventilation mode heating and cooling capacity is relative to outdoor air conditions

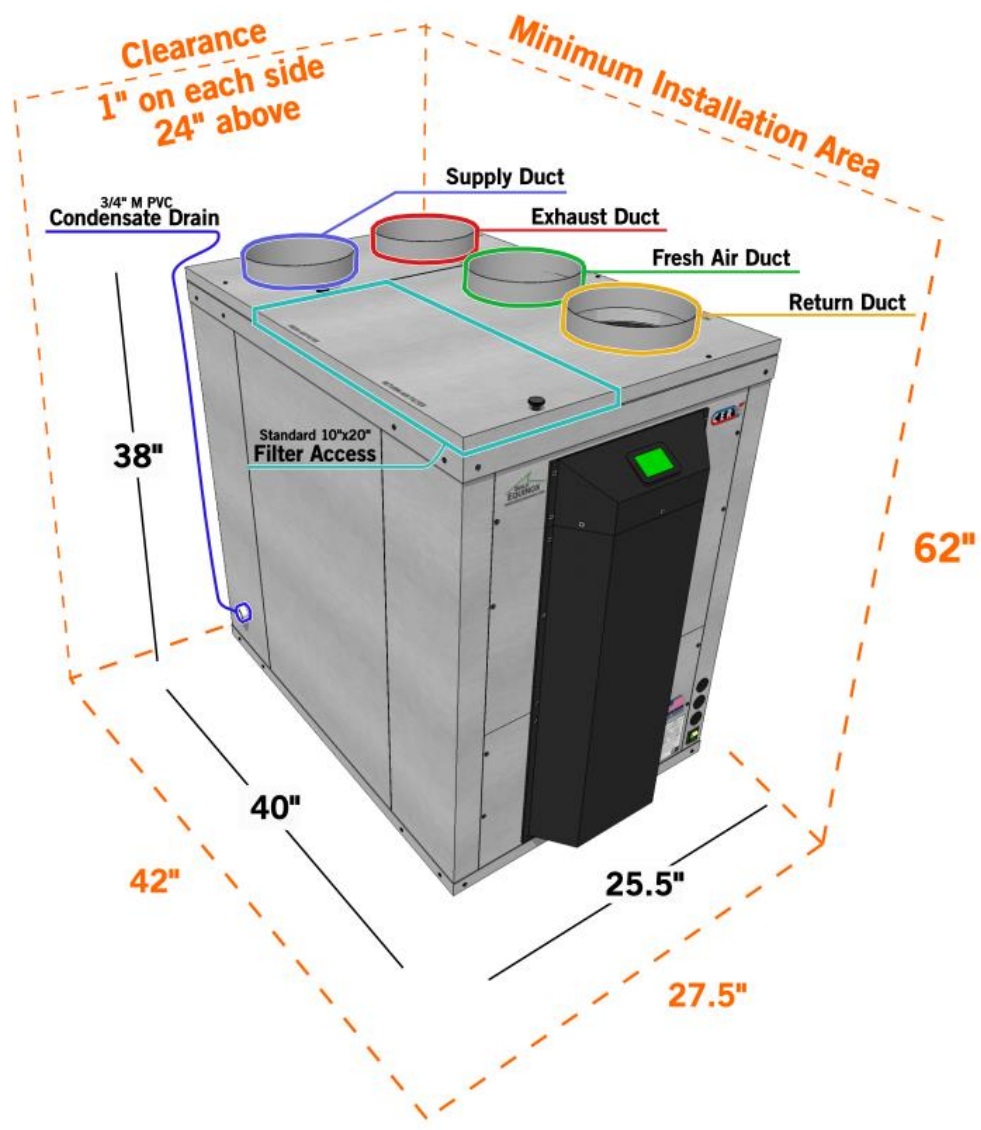
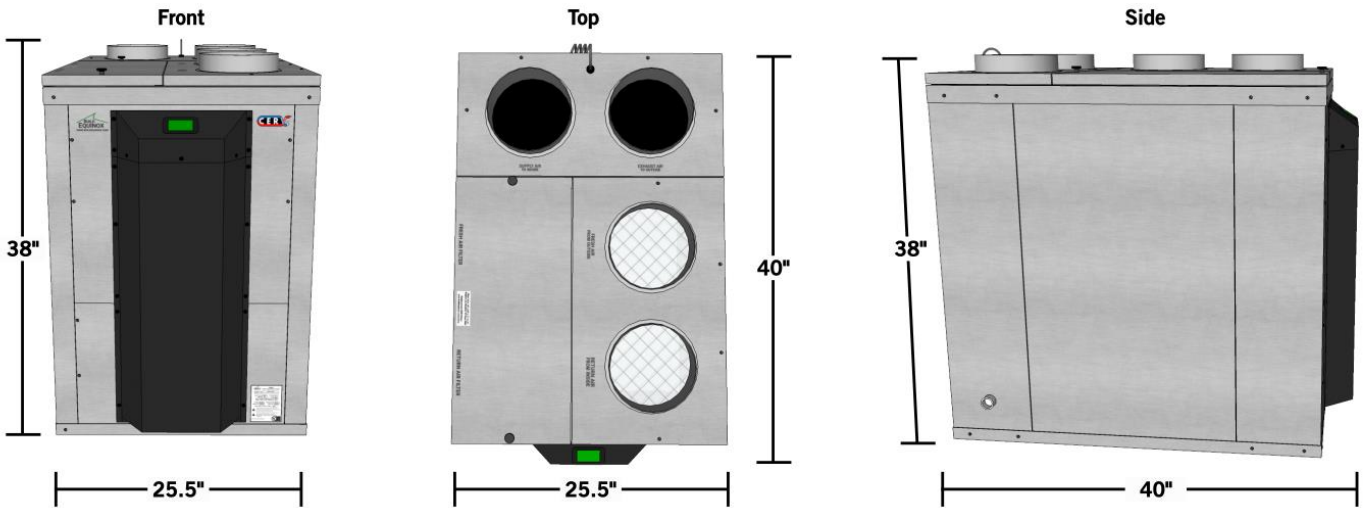

General Considerations



DANGER: Risk of electric shock. Can cause injury or death: disconnect all remote electric power supplies before servicing.

1. Please review entire manual before proceeding with installation. Improper installation or deviation from instructions can result in damage and warranty being voided.
2. Ensure that all components are on hand and free from defects or damage.
3. Installation and service should be performed by qualified personnel with a thorough understanding of electrical safety precautions. Units must be properly grounded.
4. Beware of sharp edges when assembling duct connections and do not lift CERV2 by duct fittings or front electrical enclosure.
5. Units should be secure and level. If installing on a platform, ensure levelness and structural stability of the platform.
6. Ducts must be insulated as directed in ducting section. Improper or insufficient duct insulating can lead to condensation and staining and/or water damage.
7. Water drain must be lower than the drain outlet from the CERV2 unit. If not, a condensate pump must be used.

Fresh Air Inlet & Exhaust Air Outlet Vents

1. 8" diameter ductwork is recommended, 6" minimum.
2. Must be sufficiently above ground to avoid blockage from snow or other obstructions. Two feet above ground is recommended.
3. Wall vents to the outside must use a coarse screen or mesh to prevent insects, birds, etc from entering, but fine screens, dampers, flaps, etc should be removed so as to eliminate any restrictions. Recommended wall vent: Mfr: Imperial, Part #: 6398901
4. If possible both inlet and exhaust should be on same side of house to avoid pressure differential, which can impact flow.
5. Inlet and exit ducts should be a minimum of 4' apart in any orientation. Inlet separation from any other possible sources of contamination should be considered and local codes followed.

Bathrooms & Kitchen

1. Bathroom vent fans can be used in-line with the ductwork to the CERV to boost airflow. Consider using the Active Circuit Transmitter option to trigger the CERV to vent while the fan is active.
2. Do not duct a cooktop vent hood directly in-line with ductwork to the CERV.
3. A recirculating vent hood may be used to remove grease and particulates from the air in combination with a CERV return vent in the kitchen. Any CERV kitchen return vent must be minimum 6ft from cooktop. Consider using the Active Circuit Transmitter option to trigger the CERV to vent when fan active.

Installation Procedure

Unit Installation & Ducting

1. Review Ducting section below to determine most applicable ducting scheme.
2. It is recommended to install the CERV2 in a plastic appliance basin if location is such that water damage is a concern. A clogged condensate line can cause water to pool around the CERV2. A moisture sensor and alarm can also be used to notify occupants of a problem.
3. Fix the CERV into position and ensure stability. **Unit must be level.** Vibration feet (not provided) can be placed under CERV to reduce vibration and to keep CERV off of a potentially wet floor surface.

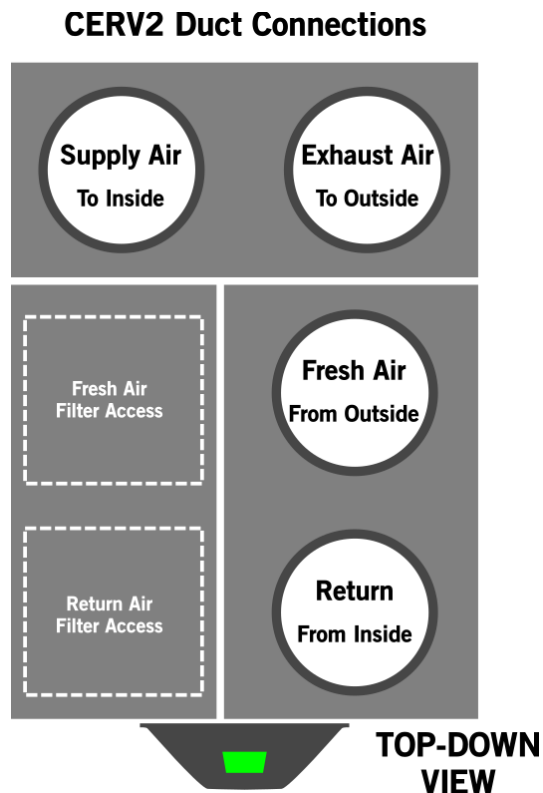

Insulating

In the winter, the unit will be bringing in cold air, passing it through the heat pump, and then exhausting EVEN COLDER air. In the summer, the CERV will be bringing in hot air, passing through the heat pump, and exhausting EVEN HOTTER air. It is therefore extremely important that the components of the system are properly insulated, as to prevent any condensation on the ducting.

Ducts

All ducts except for the RETURN (from inside) must be insulated. It is recommended to use a minimum of R4.0 insulation for supply to the inside and R8.0 on the ducts to and from the outside. In colder climates, it may be necessary to add additional insulation if it appears that the ducts may be showing signs of sweating.

Ducting Example #1:

CERV2 with Dedicated Return & Supply Ductwork

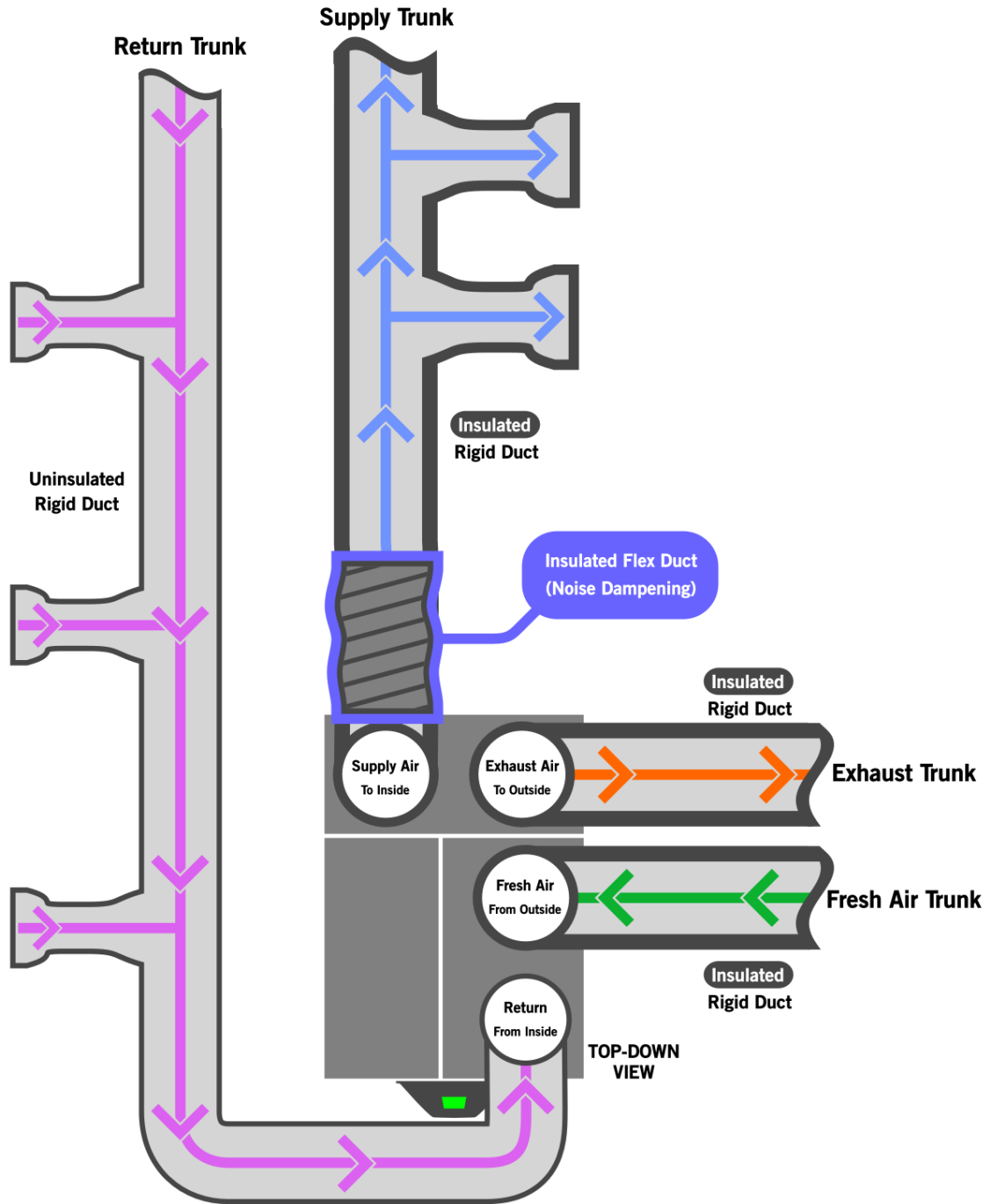

Ducting Example #2:

CERV2 Connected to Forced Air System
Dedicated CERV Return
CERV Supply to Forced Air System Return

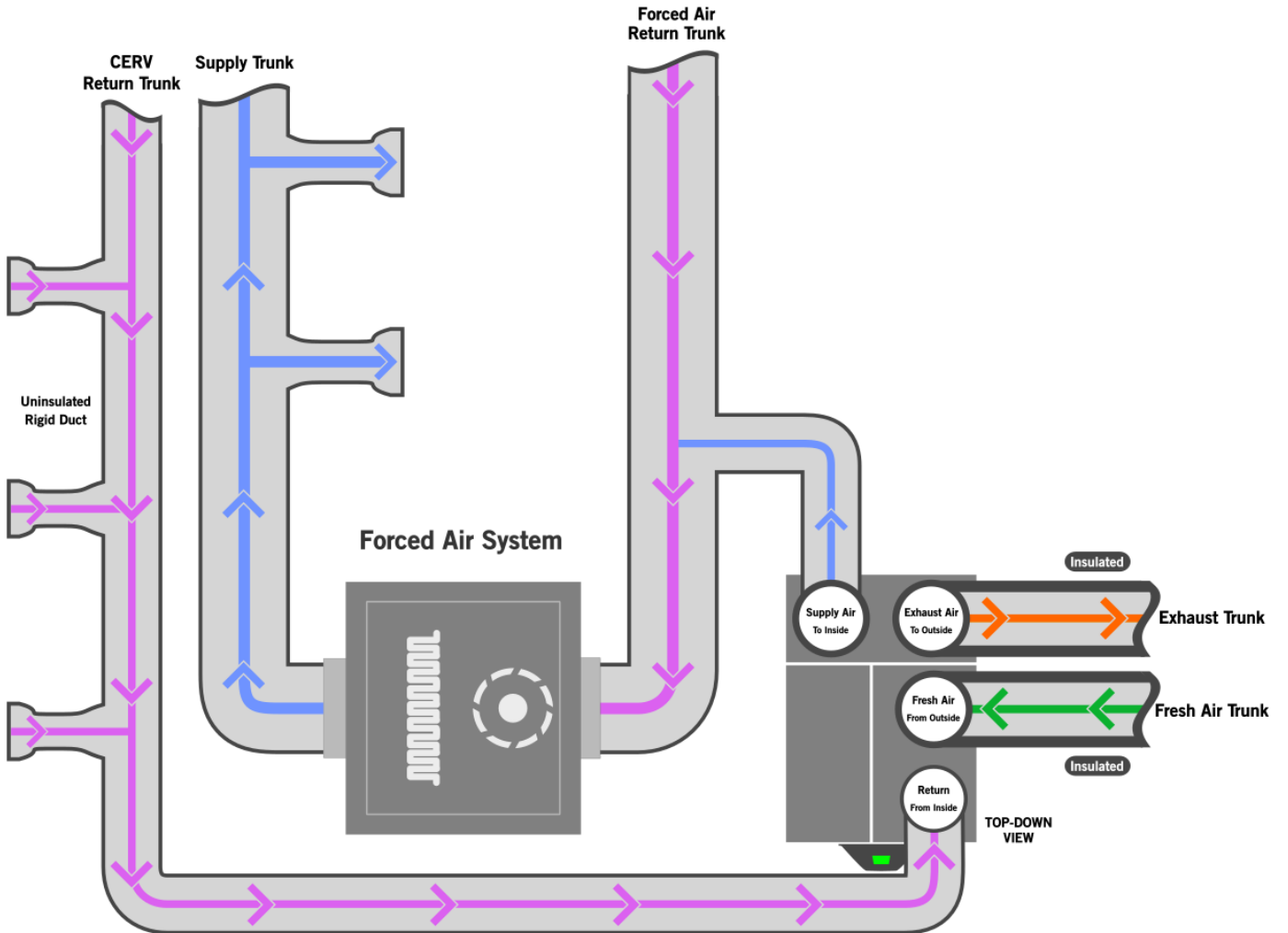

Ducting Example #3:

CERV2 Connected to Forced Air System
Dedicated CERV Return
CERV Supply to Forced Air System Supply
Backdraft Damper Required

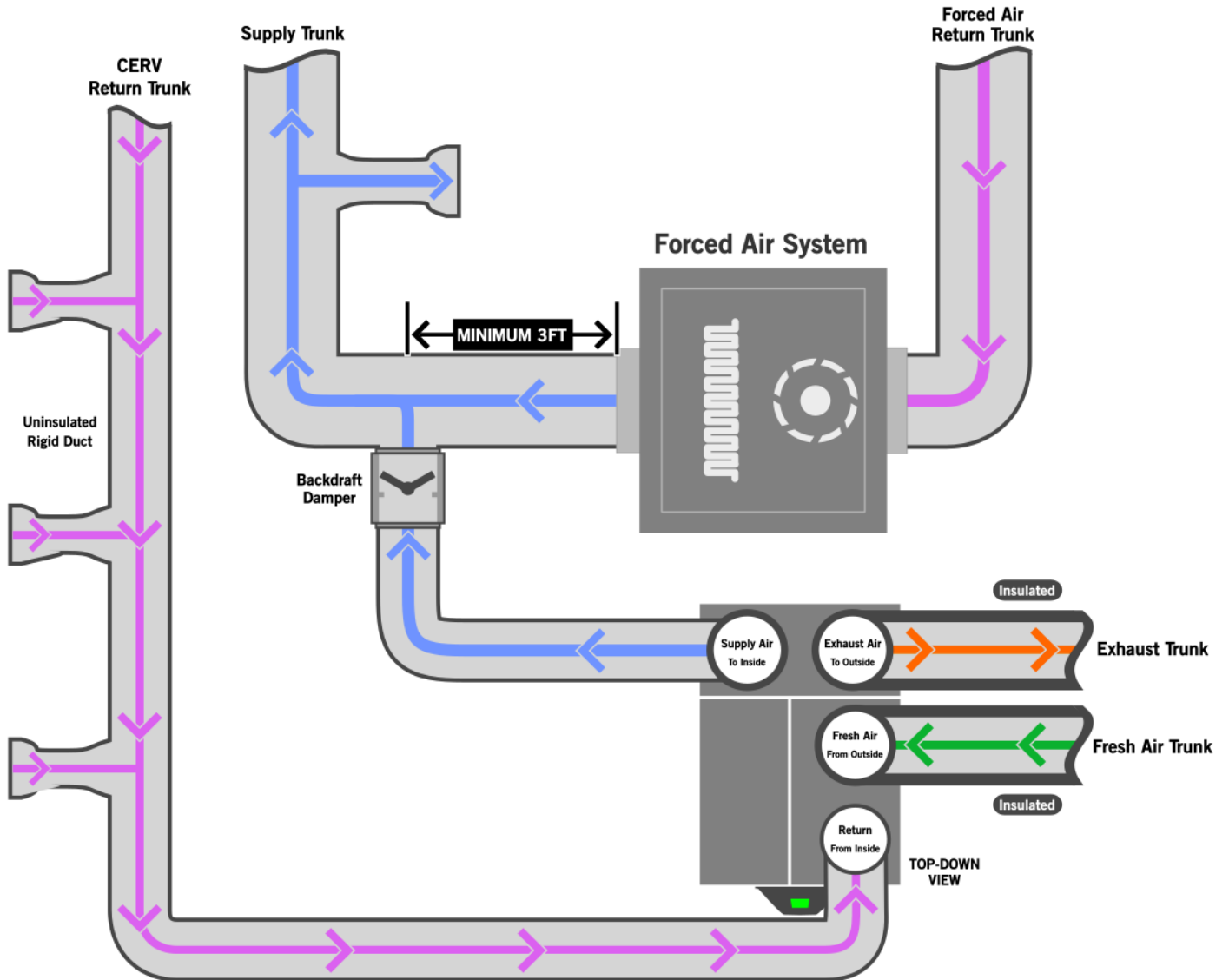

Ducting Example #4:

CERV2 Connected to Forced Air System
CERV Return from Forced Air System Return
CERV Supply to Forced Air System Return

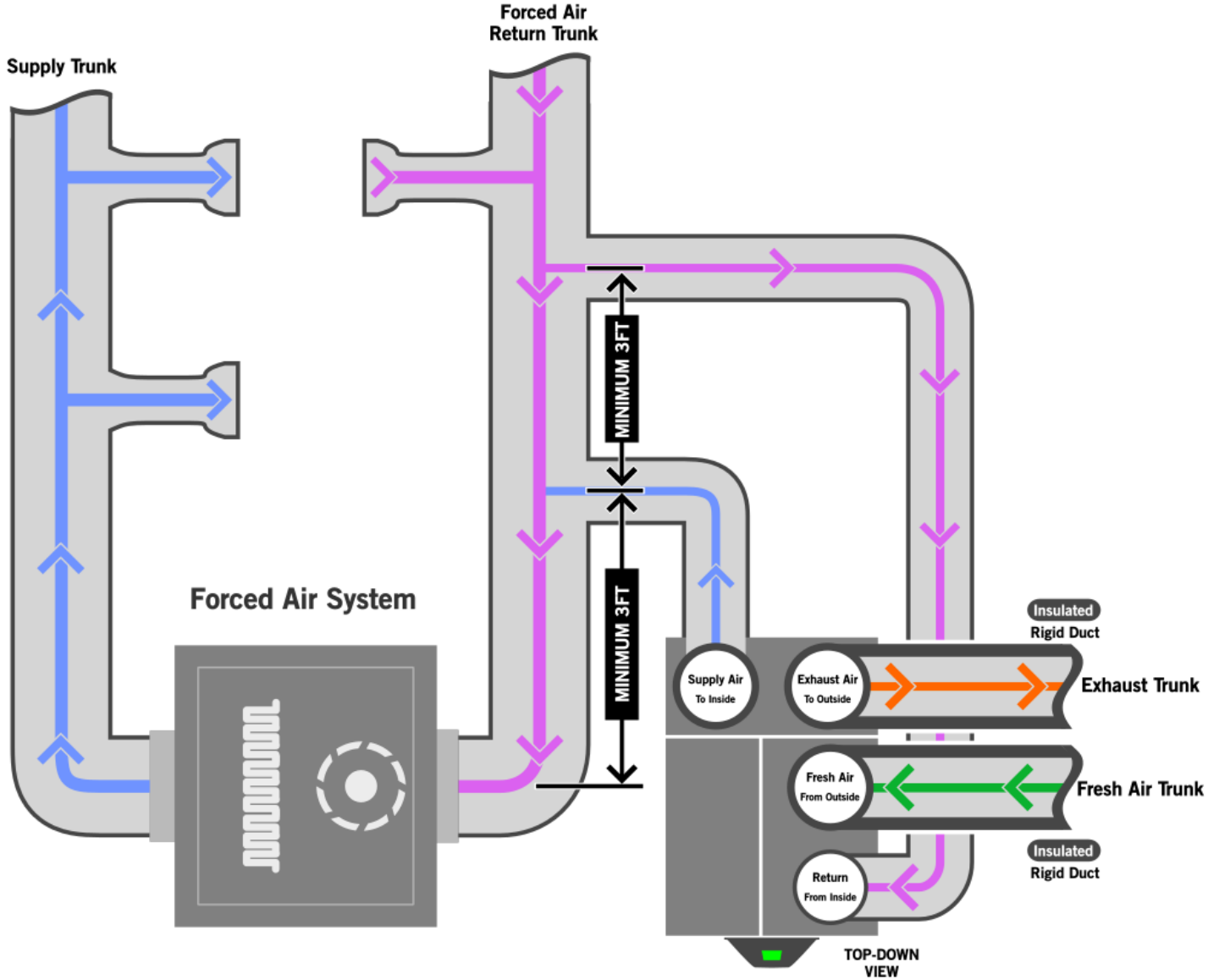

Water Drain

1. The CERV should be spaced raised up approximately 2 inches from the ground to allow space for the included EZ-Trap
2. The outlet of the EZ-trap should direct either to a floor drain, or condensate pump

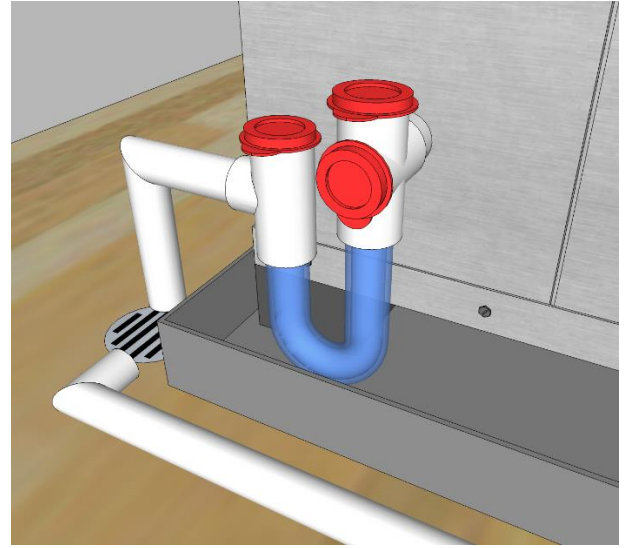
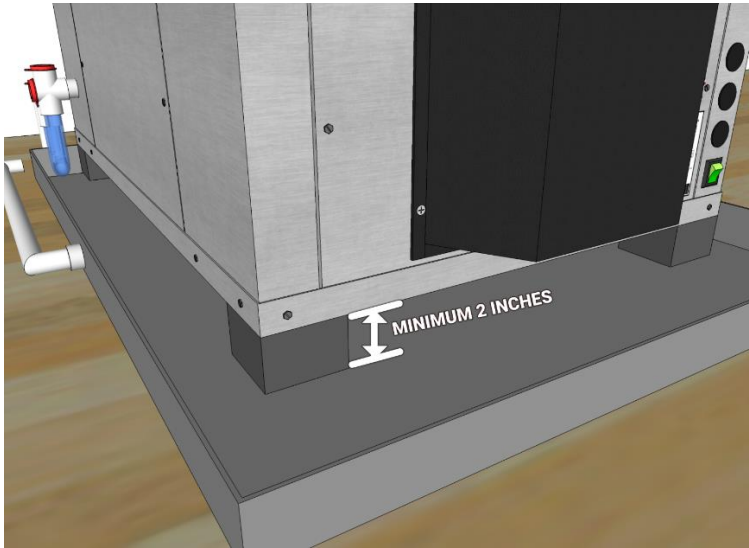

Overflow Pan

For installations where water damage could be a possibility (i.e. finished spaces, attic, etc), an overflow pan should be placed under the CERV. If using a pan, the pan should also have a drain tube installed.



Recommended Drain Pan: DiversiTech 6-2739L

Pan Dimensions: 29" x 41" x 2"

Wet Switch

For added protection, a wet switch may be installed in the drain pan or base of the CERV. Two options exist for wet switch configuration.

Direct Power Cutoff

It is highly recommended to completely remove power to the CERV2 if water in the overflow pan is detected, protecting the electronics inside the CERV from damage. Consider the use of a product like the [Hydro Check WaterWatcher](#). The device will shut off the CERV, as well as sound an audible alarm if water is detected in the overflow pan.



Auxiliary Input – Halt Operation

A Normally Closed moisture detection switch may be used to trigger the Halt Operation functionality of the CERV's Auxiliary Input(s). See appendix for Auxiliary Input location and access.

Touchscreen Configuration

Wired Auxiliary Input Overview

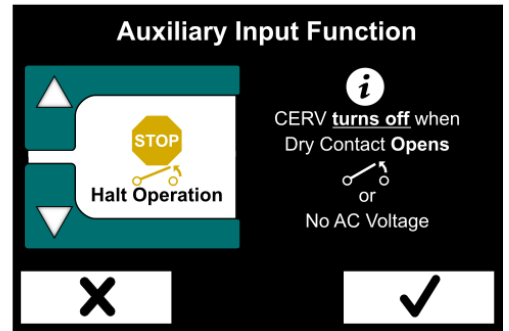
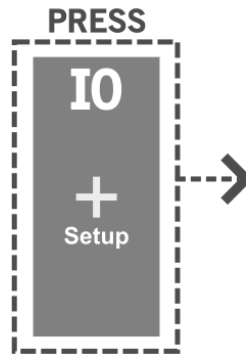
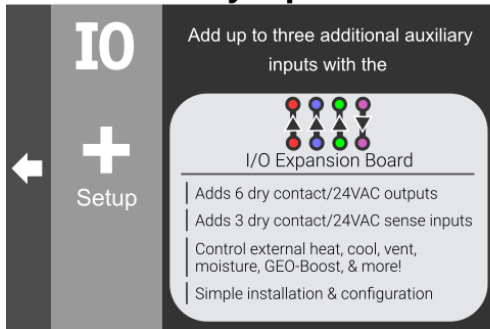

Set the input channel for I/O to Halt Operation (Turns OFF why dry contact open)

Wet Switch Circuit

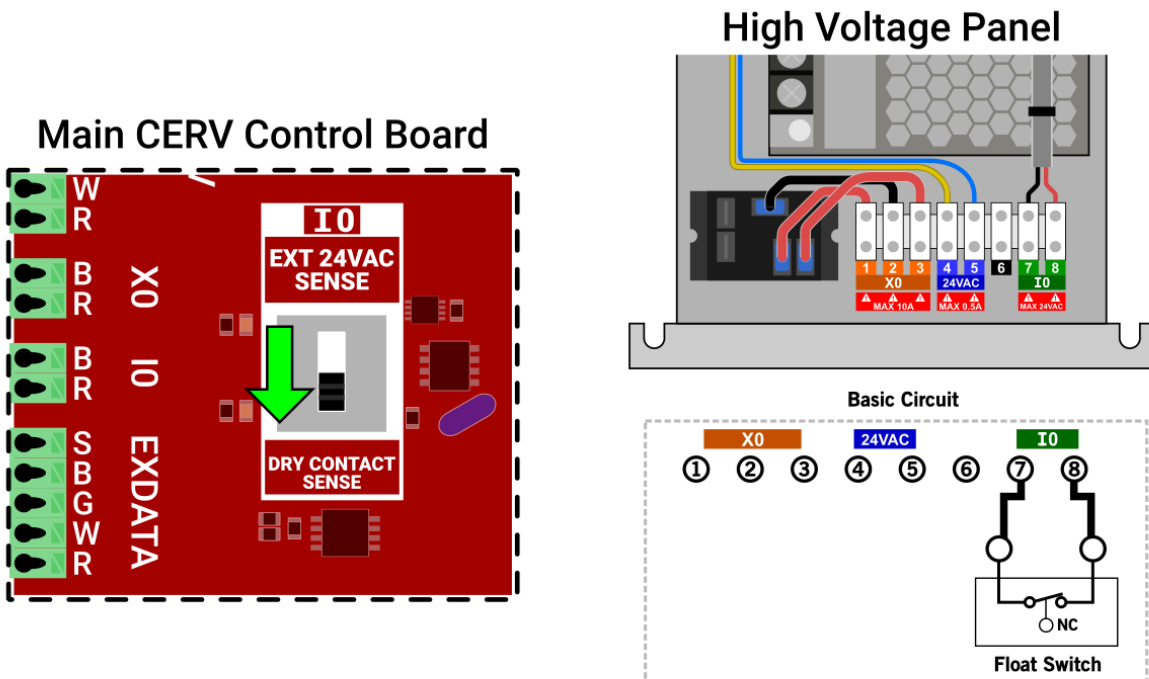

When safety switch is OK (no water), Switch is CLOSED
When safety switch faults, Switch is OPEN, system shuts down

Electrical



DANGER: risk of electric shock. Can cause injury or death: disconnect all remote electric power supplies before servicing.

Electrical Ratings

Voltage Supply	120VAC (60hz)
Minimum Circuit Size	12A
Connection	Standard NEMA 5-15P Plug, 6ft Cord

General Wiring Guidelines

- All electrical wiring should be performed as to comply with National Electric Code NFPA 70. Additionally, be aware of any additional city or utility code requirements before installation. Units must be properly grounded.
- Supplied power to the unit must comply with the nameplate requirements.
- The CERV should have its own dedicated circuit.
 - The circuit supplying the CERV **SHOULD NOT** have a GFCI outlet or GFCI circuit breaker. The CERV contains variable speed fans and a variable speed heat pump inverter, which can lead to false trips on the GFCI devices.
 - If the CERV is installed in an area that would normally require a GFCI outlet (laundry / sink / etc. nearby), the CERV should be hard-wired to the circuit instead of plugging in.
- Never run control wiring and power wiring through the same conduit.
- Always use proper gauge stranded copper wire for power connections.

Electrical Installation

1. With the CERV unplugged, install any auxiliary field wiring to the unit. The CERV includes three standard $\frac{3}{4}$ " electrical knockouts, directly above the power switch. These should be used, along with strain relief fittings, for any auxiliary input or output connections. See Appendix at the end of the document for auxiliary wiring guidelines and specific examples.
2. Ensure that the front power switch on the CERV is OFF. The green rocker power switch should be in the DOWN position.
3. The CERV plugs into a standard North American 3 prong outlet (non-gfci) and is supplied with 6 feet of power cord. Plug the CERV into its dedicated power outlet. As per the general wiring guidelines above, if the CERV is installed in a location that would normally require a GFCI outlet, it should be hard-wired to the circuit instead of plugged in.

Regular Maintenance

The CERV2 has several recommended maintenance items to ensure the health and performance of the system. The maintenance items can be found detailed in the included CERV2 Maintenance Guide ([link](#)) Regular maintenance should be performed approximately every 90 days.

Filters

The CERV2 contains filters for both incoming fresh air from outside and return air from inside. The filters can be easily accessed by unscrewing the top two thumb-screws and removing the top filter access cover. When replacing the filters, care should be made not to drop any object into the openings.

The CERV2 comes standard with two MERV 13, 10"x20"x1" filters. Any 10"x20" filter 1" or 2" thick can be used, although using filters higher than MERV 13 can cause higher fan power for little gain in filtration. Ensure that the filter direction corresponds to the airflow direction sticker on the inside of the CERV (points down). Filters should be replaced at least every 90 days, but indoor and outdoor particulate levels may necessitate more frequent changing. The inside and outside filters may also have different changing schedules. The return air filter may need less frequent changing than the fresh air filter.

Regular filter maintenance is important in keeping the inside air healthy and free from particulates as well as allowing for peak system operating efficiency.



CERV OEM Filter Store

Keep your air filtered and healthy all year long!



OEM CERV filter can be purchased at www.buildequinox.com/store/

Touchscreen Controller – Changing Filters

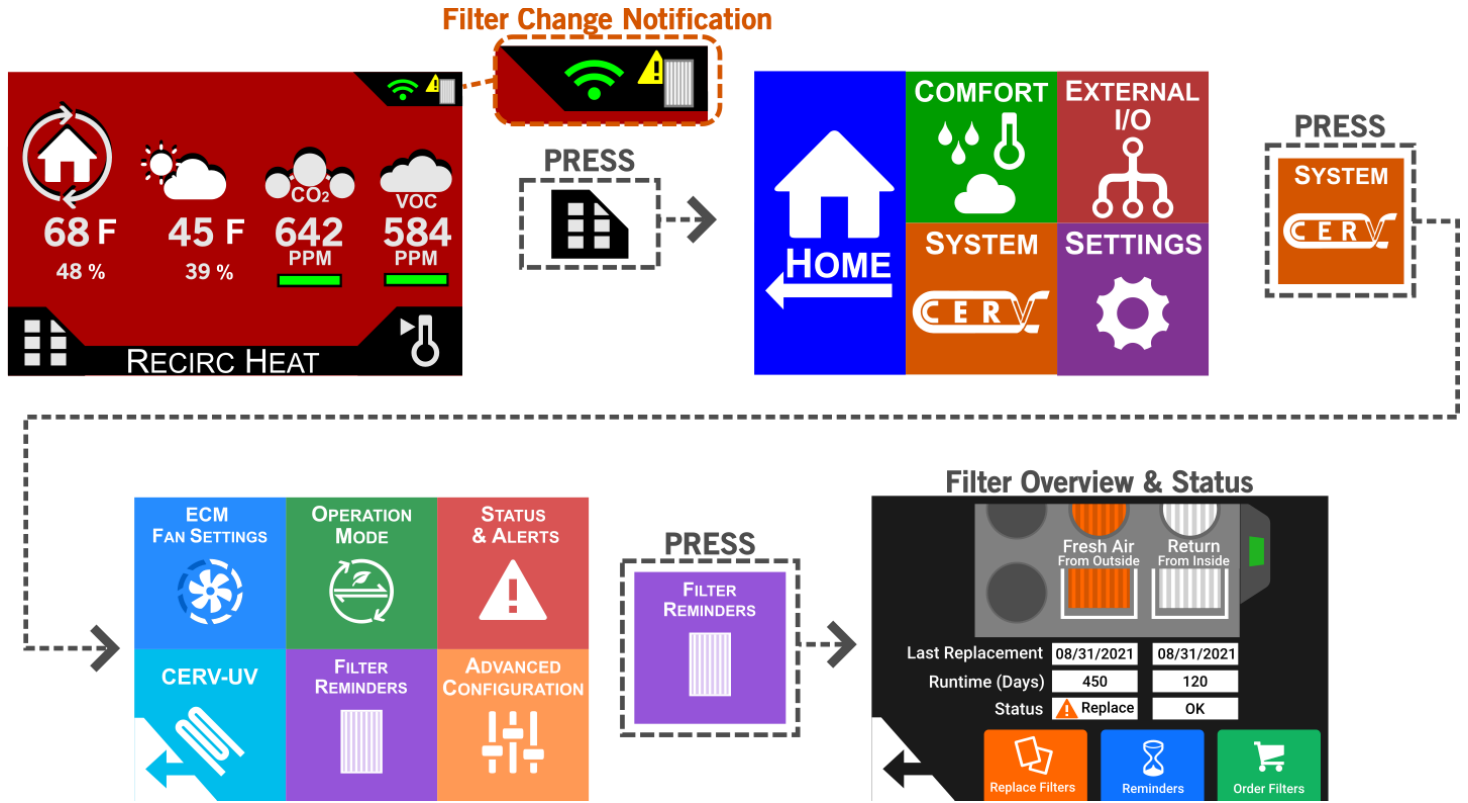

Press the “Replace Filters” button to begin the filter replacement procedure. The screen will walk you through the process. At the end, input the current date.



Press the “Reminders” to configure the frequency of filter notifications on your CERV

Accessing Filters for Replacement

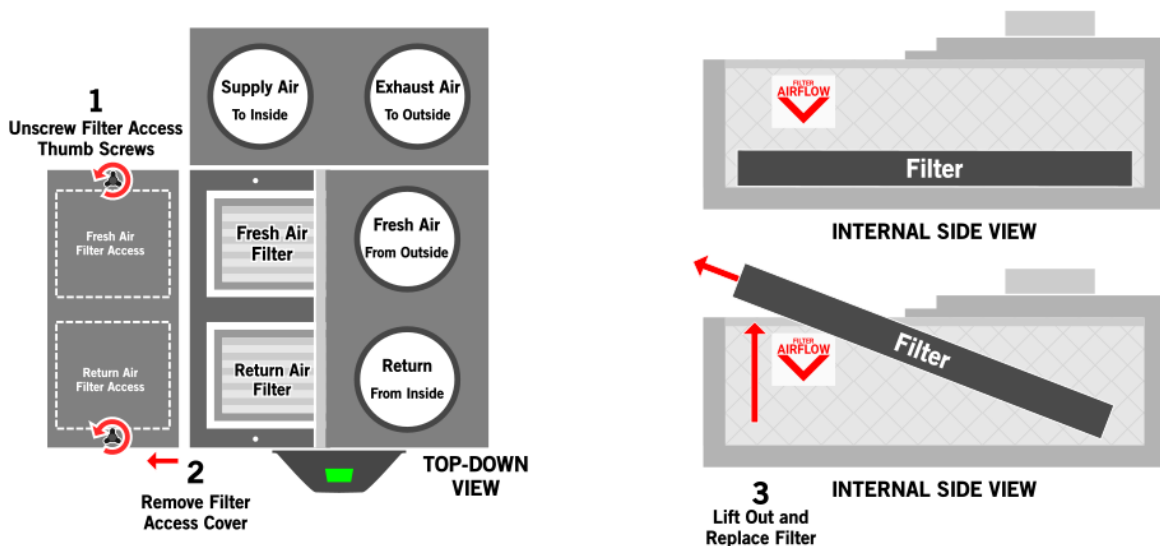

Starting and Commissioning the System

Please review all ducting, insulating, condensate drain, and electrical sections before continuing. After all electrical wiring has been completed and all connections have been double checked, apply power to the unit. When the unit is first started, it takes approximately 30 seconds to initialize valves and check system health.

For the first 3 minutes after initialization, the CERV will go into an Assess mode. In this mode, it recirculates air throughout the home and compares to the configured heating, cooling, and ventilation setpoints. For commissioning the unit, it is important to check the following features of the unit:

Touch Screen Interface

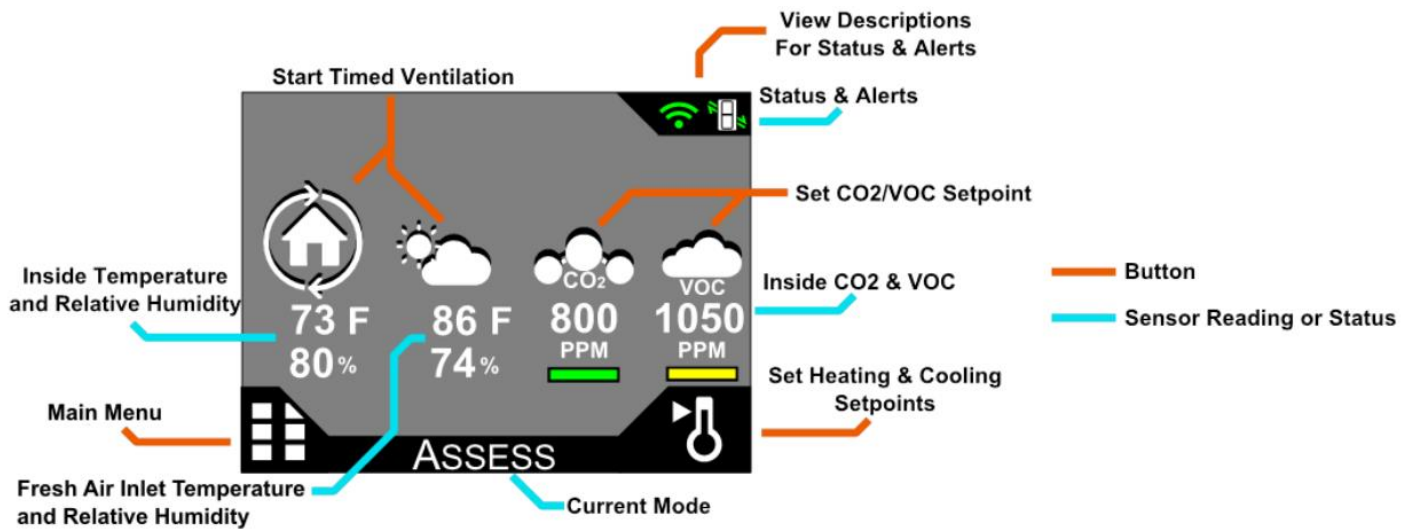

1. The CERV logo will initially show on the screen, and then after approximately 15 seconds, you will enter the home screen. This screen displays the inside and outside temperature and relative humidity, as well as the CO2 and VOC indoor air quality levels.
2. In the top right corner of the home screen, there is a small WiFi connectivity icon. For information regarding setting up the connection to your home router, please see the Appendix.
3. Once the wireless connectivity icon turns green, the CERV has successfully connected to the online server and is ready to control through your computer or mobile device anywhere in the world!

ECM Fan Speed Configuration

The fan speed has been factory set to 50%. If airflow measurements are being taken for commissioning purposes the fan speed can be increased or decreased by following the steps in the Appendix.

Connection Status Troubleshooting

WiFi Connection Error	Probable Cause & Resolution
<p>Couldn't Find SSID</p>	<ul style="list-style-type: none"> • If Manual setup was used to connect to the WiFi Network, check for misspellings in the network name and try again. • On another device (phone/laptop/etc), check that the network exists and is exactly as entered on the CERV. • The CERV currently only operates on 2.4GHz WiFi networks. 5GHz WiFi is not supported at this time.
<p>Incorrect Password</p>	<ul style="list-style-type: none"> • If Manual setup was used to connect to the WiFi Network, check to ensure the network security is correctly set. Most modern WiFi networks use WPA2. This can often be verified with on a computer or phone by examining network properties. • Ensure that the entered password is correct.
<p>Timed out - try again</p>	<ul style="list-style-type: none"> • There may be an issue with the internal WiFi configuration, and the connection attempt timed out. • Press the checkbox button on the bottom of the screen, which will take you back to the "Getting WiFi Status" screen. Stay on this screen for a minute to see if it was able to recover and make the connection. If not, try adding the network again as before. • If re-adding the network gives the same timed out error, try powering off the CERV, then back on, and adding the network again. Resetting power to the internal WiFi could potentially resolve the issue.
<p>No Connection to Internet Or No Connection to Server</p>	<ul style="list-style-type: none"> • Connection to the WiFi network was successful, but the CERV is having trouble uploading data through the internet. This often resolves itself after several minutes (depending on the network). Contact Build Equinox if this does not resolve itself.

Appendix – Wi-Fi Setup Alternative: Computer or Mobile Device

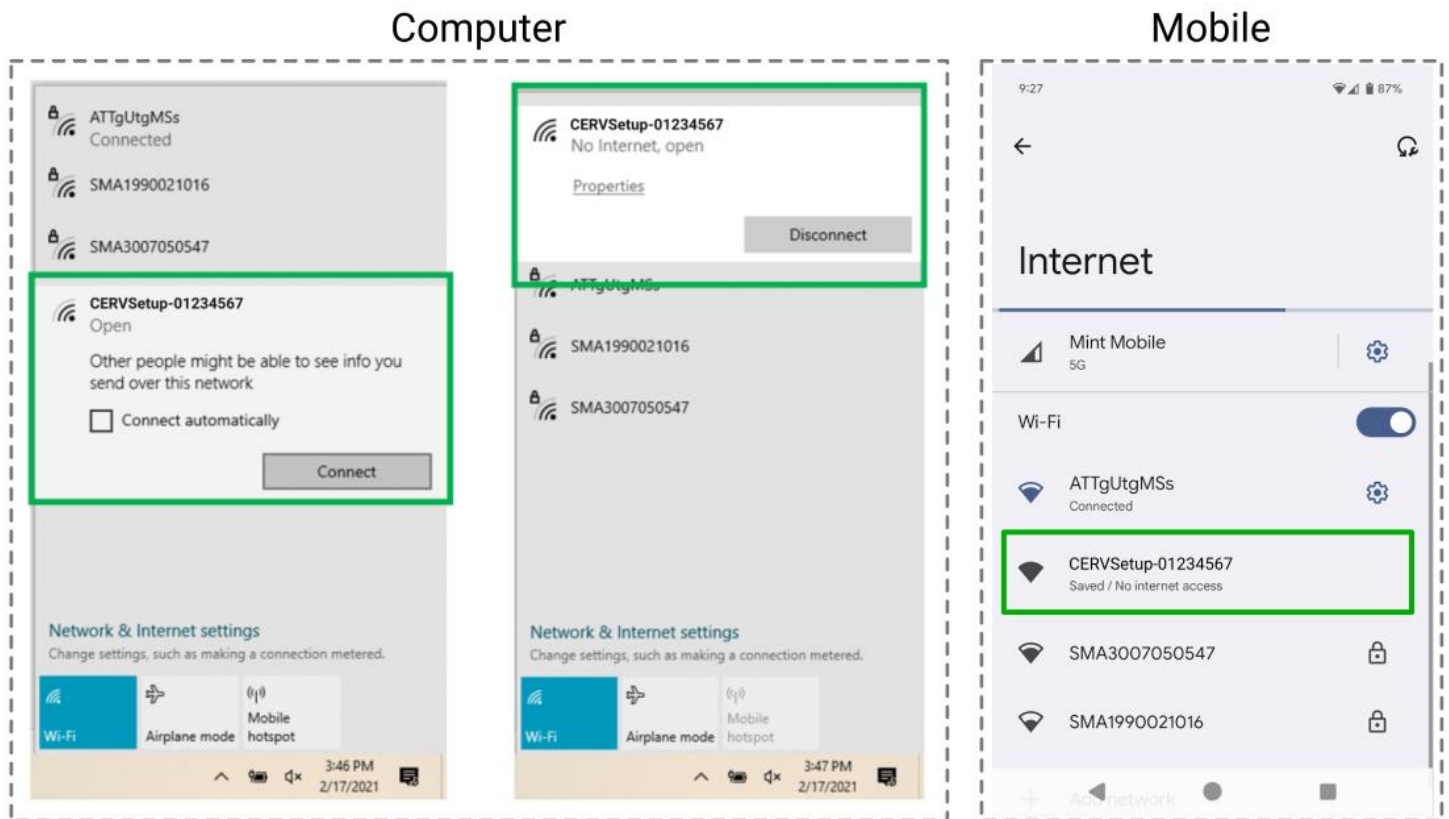

Step 1:

Computer: On your computer, click the status bar icon, then the wifi connection icon. If the wifi module on the CERV is not yet connected to a wifi network, you will see it here as a network called “CERVSetup-_____”. Select the CERVSetup-_____ network, and click Connect.

Mobile: On your mobile device, go to your Settings, then WiFi networks. If the wifi module on the CERV is not yet connected to a wifi network, you will see it here as a network called “CERVSetup-_____”. Tap on the CERVSetup-_____ network.

Important Note: Earlier CERV2 systems use a different Wi-Fi Module – if instead of “CERVSetup-_____” you see a network named “xbee-_____”, skip ahead to the **Wi-Fi Setup Alternative (Legacy) – Laptop or Mobile Device** section.

Once connected, your computer or cell-phone should automatically open the Wi-Fi Connection Wizard webpage. If not, open your browser, and enter: <http://192.168.4.1/>

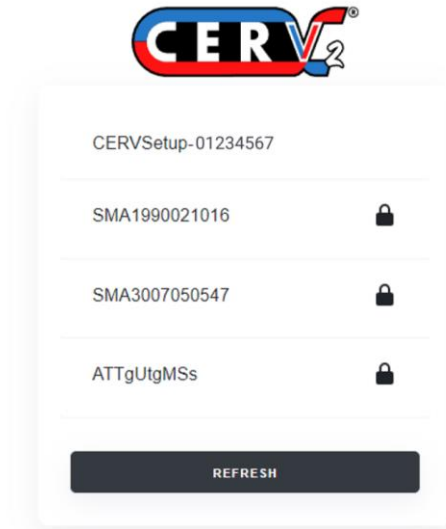

Step 2: You should now see any available 2.4Ghz Wi-Fi networks. Select the Wi-Fi network that you would like to use with your CERV2.

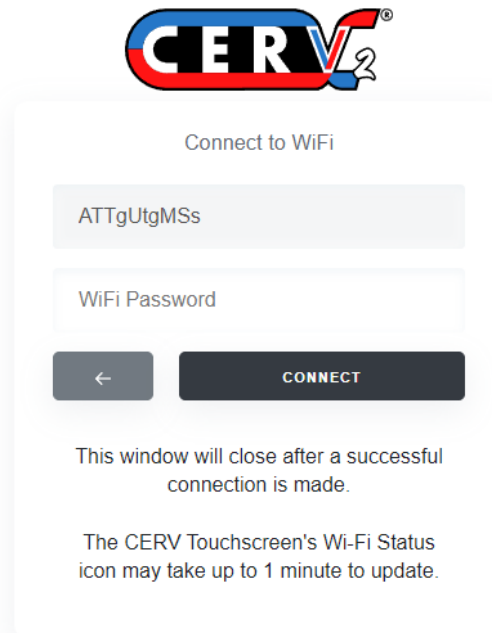

Step 3: Once you have selected a Wi-Fi network, you will now be prompted to enter the password.

If the Wi-Fi network credentials are correct, you should see your device disconnect from the CERVSetup-_____ network. You may now proceed to the **CERV-ICE Online Control & Monitoring Account Setup** section.

Appendix - CERV-ICE Online Control & Monitoring Account Setup

A free CERV-ICE account can be created to view data and air quality analytics for your CERV2 and to control your system remotely. To create an account, navigate to <https://buildequinox.com/cervice/>

CERV-ICE is also available as a free app in the Apple Store or Google Play. Search for CERV or click on the links below.

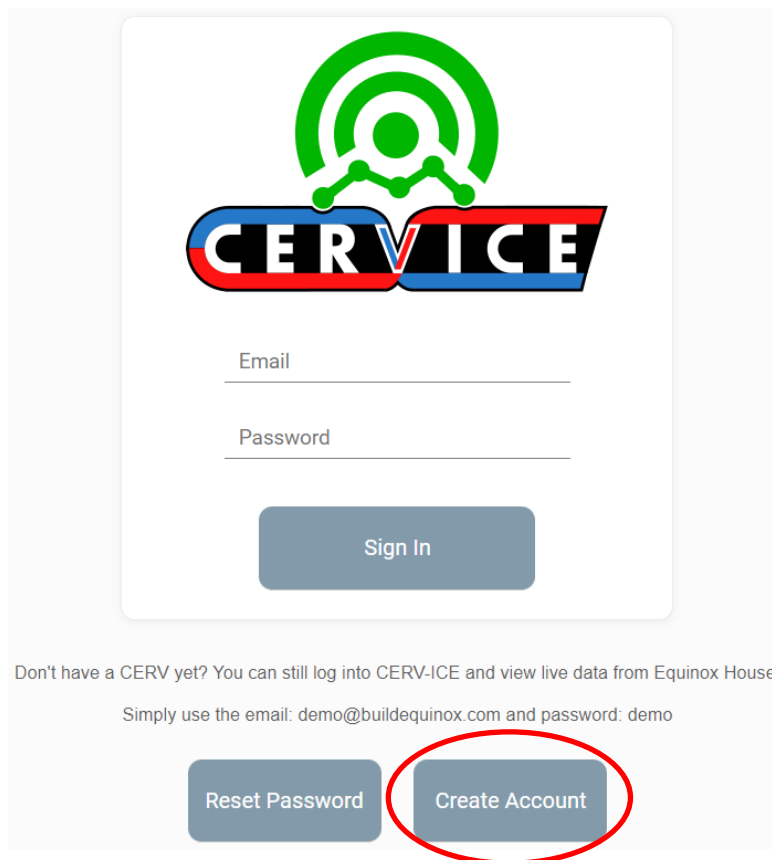

On the CERV-ICE login page or in the app click the Create Account button.

A screenshot of the CERV-ICE login page. At the top is the CERV-ICE logo, which consists of a green circular icon with a white center and a white line graph, positioned above the word "CERV-ICE" in a stylized font with red and blue horizontal stripes. Below the logo are two input fields: "Email" and "Password". A "Sign In" button is located below the password field. At the bottom of the page, there are two buttons: "Reset Password" and "Create Account". The "Create Account" button is circled in red. Below the "Create Account" button, there is a line of text: "Don't have a CERV yet? You can still log into CERV-ICE and view live data from Equinox House! Simply use the email: demo@buildequinox.com and password: demo".

The create account wizard will now guide you through the account setup process.

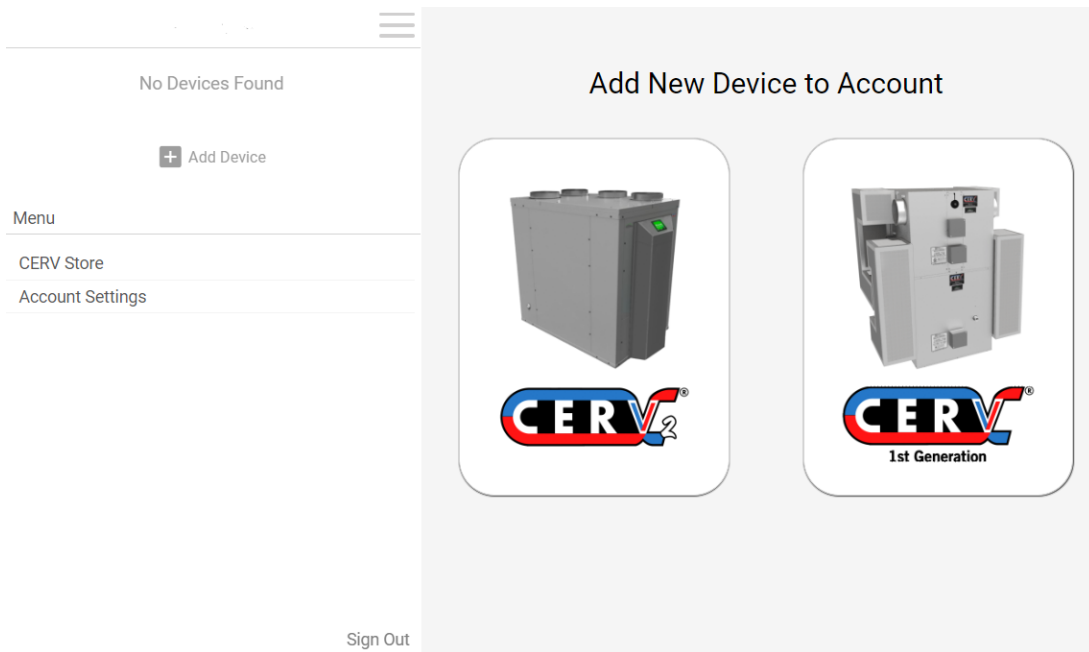

Once logged into your CERV-ICE account, select your CERV model, name your device, and enter the CERV's 12-digit "Gateway Serial Number".

The Gateway Serial Number can be found on the CERV's Wi-Fi configuration page:

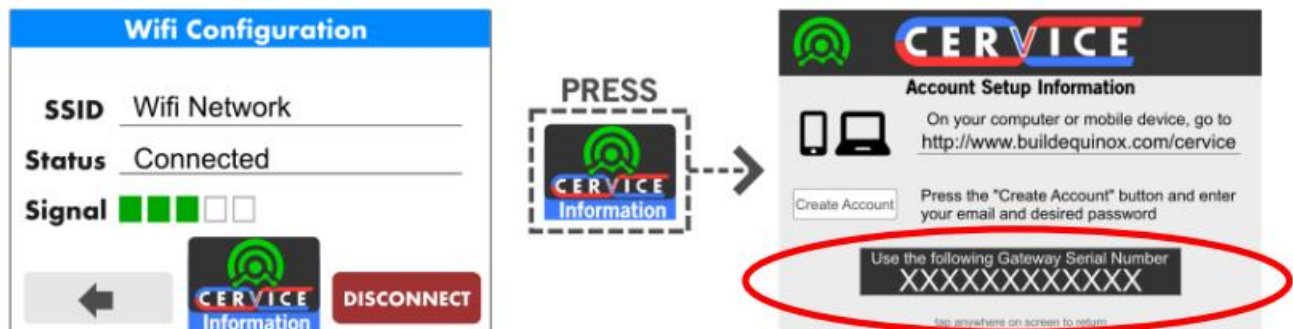

Appendix – Fan Speed Configuration

The inline fans included with the CERV can be configured to help maximize comfort and fresh air delivery to the home. There are three configuration settings for the inline fans:

- **Normal Operation:** This will be the default fan speed for the system as it ventilates, recirculates, heats, and cools your home. In Recirculation Heating and Recirculation Cooling modes, the outside fan may increase to a higher speed to help boost the efficiency and capacity of the CERV.
- **Triggered Ventilation:** If a wireless switch is pressed to trigger a ventilation period, the fans will increase to the Triggered Ventilation fan speed setting. This fan speed setting also applies if you start a timed ventilation event from the wireless controller.
- **Scheduled Recirculation:** When no heating, cooling, or ventilation is needed, but the Scheduled Recirculation setting is greater than 0%, the inside fan will recirculate air throughout the home. This fan speed setting allows you to recirculate at a higher or lower airflow than normal operation.

The user may also specify a supply/exhaust fan balance setting for the system. If the fan balance setting is nonzero, the exhaust fan will run higher or lower than the supply fan while ventilating in order to compensate for ducting losses for balanced ventilation. For example, if the user sets a -10% fan balance, and the “Normal Operation” fan speed is 50%, if the CERV is ventilating due to VOC or CO2 levels, the supply fan to the home would run at 50%, and the exhaust would run at 40%. With a +10% fan balance, the supply would be 50% and exhaust would be 60%.

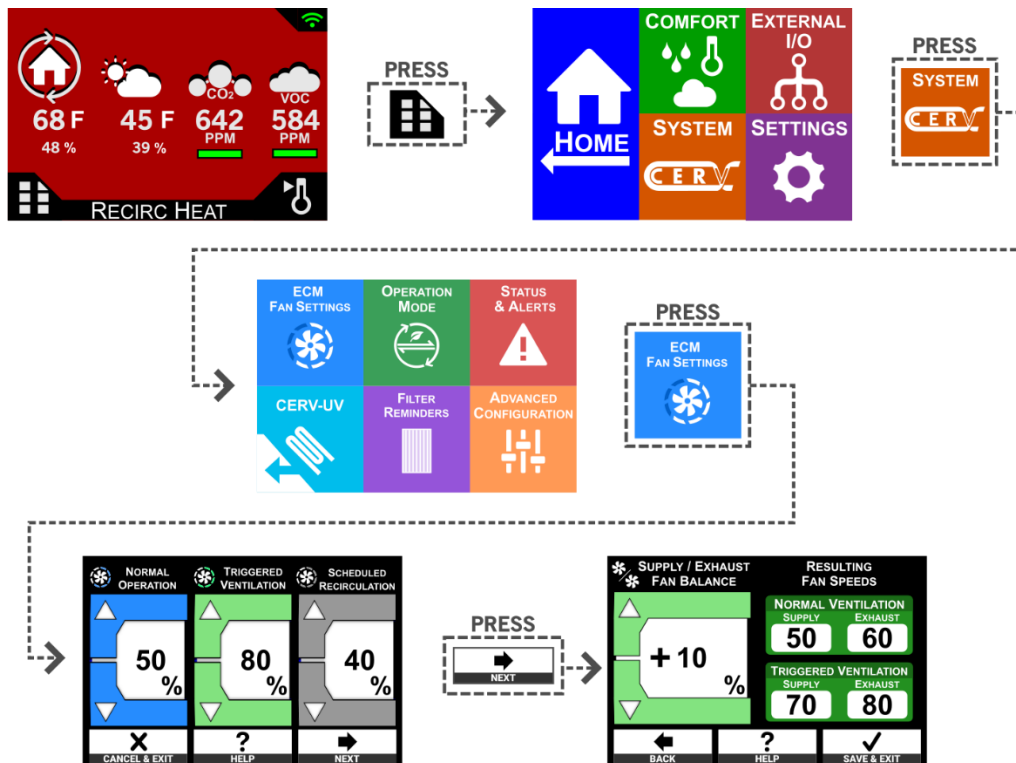

Appendix - Electrical

DANGER: risk of electric shock. Can cause injury or death: disconnect all remote electric power supplies before servicing.

CERV Internal Wiring Diagram

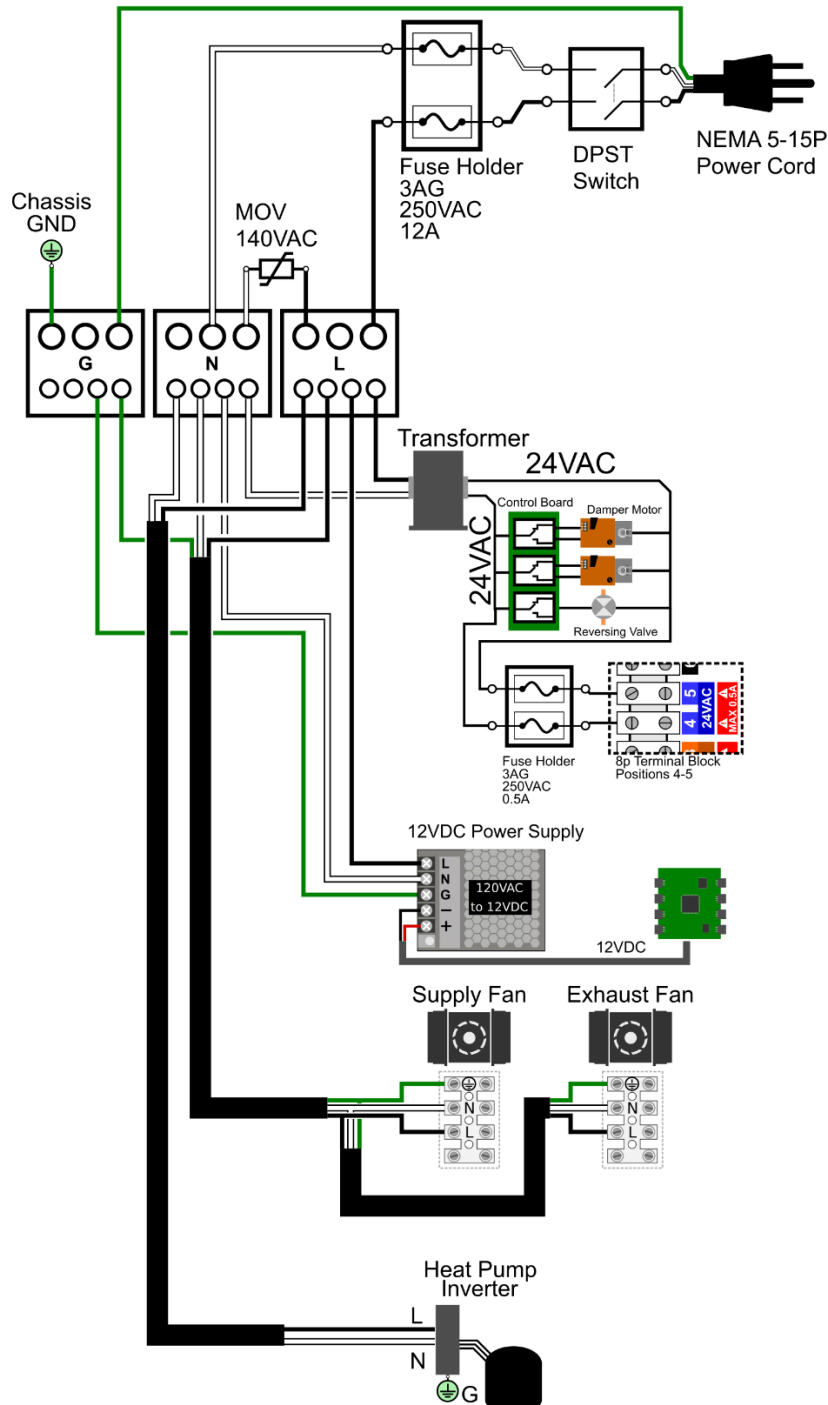

Front Panel Removal and Auxiliary Input/Output (X0 and I0) Access

These instructions show how to access the internal input/output connections in the CERV2. Before removing any access covers, power to the CERV2 should be turned off and the unit either unplugged or the electric breaker switched off. Remove the lower front plastic cover by removing the 13 phillips head screws shown below.

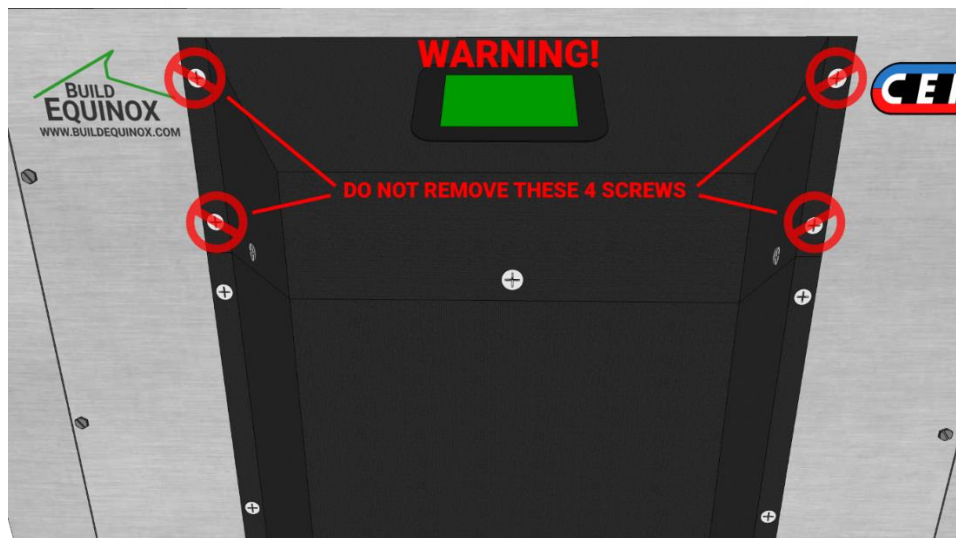
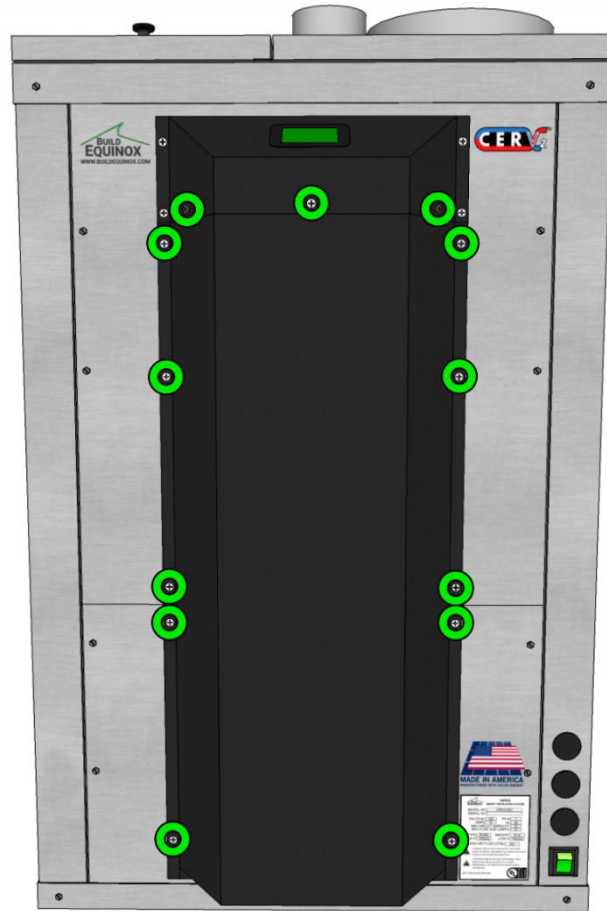

Once the lower front cover is off, the four screws for the lower access panel can be removed. Screw locations are shown below. With the screws removed, the panel will be free to come out.

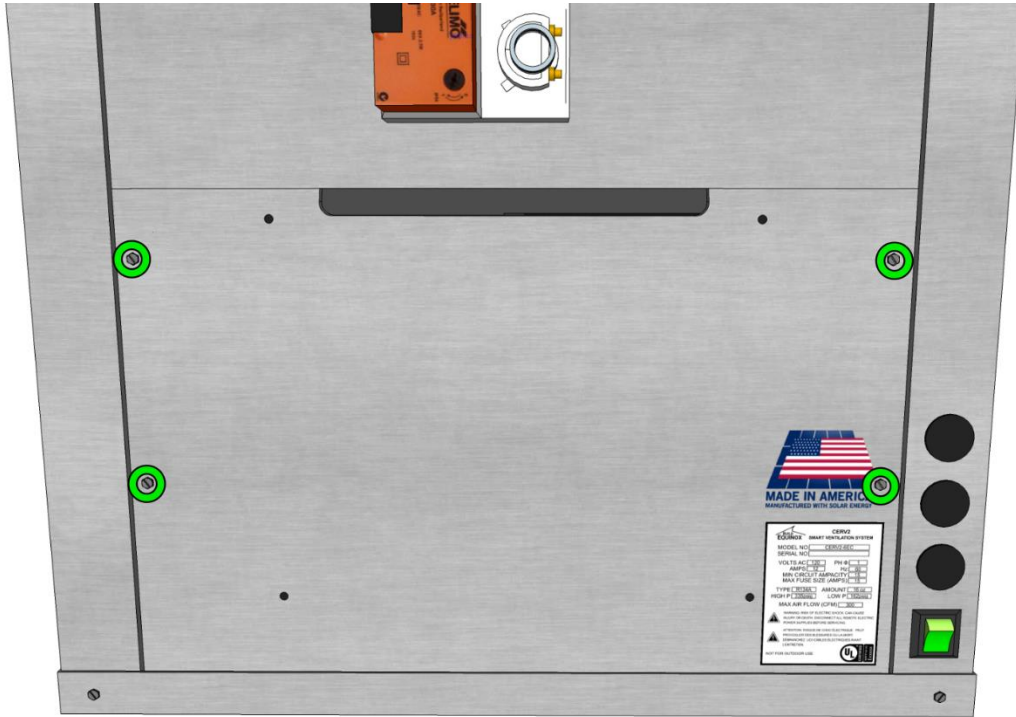

On the right side is the power conditioning and distribution electronics assembly. The I/O terminals are located at the front of this assembly. Three 3/4" knockouts are provided for running wires to the I/O terminals. Conduit or wire strain relief fittings should be used in these knockouts.

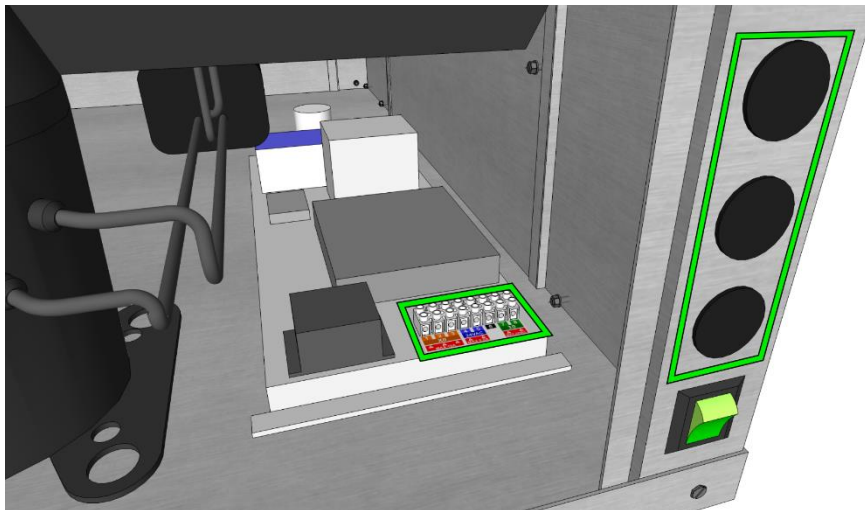

Built-In Auxiliary Input and Output (X0 and I0)

A schematic of the I/O terminals is shown below. The following sections describe making wired connections to these terminals for several external devices.

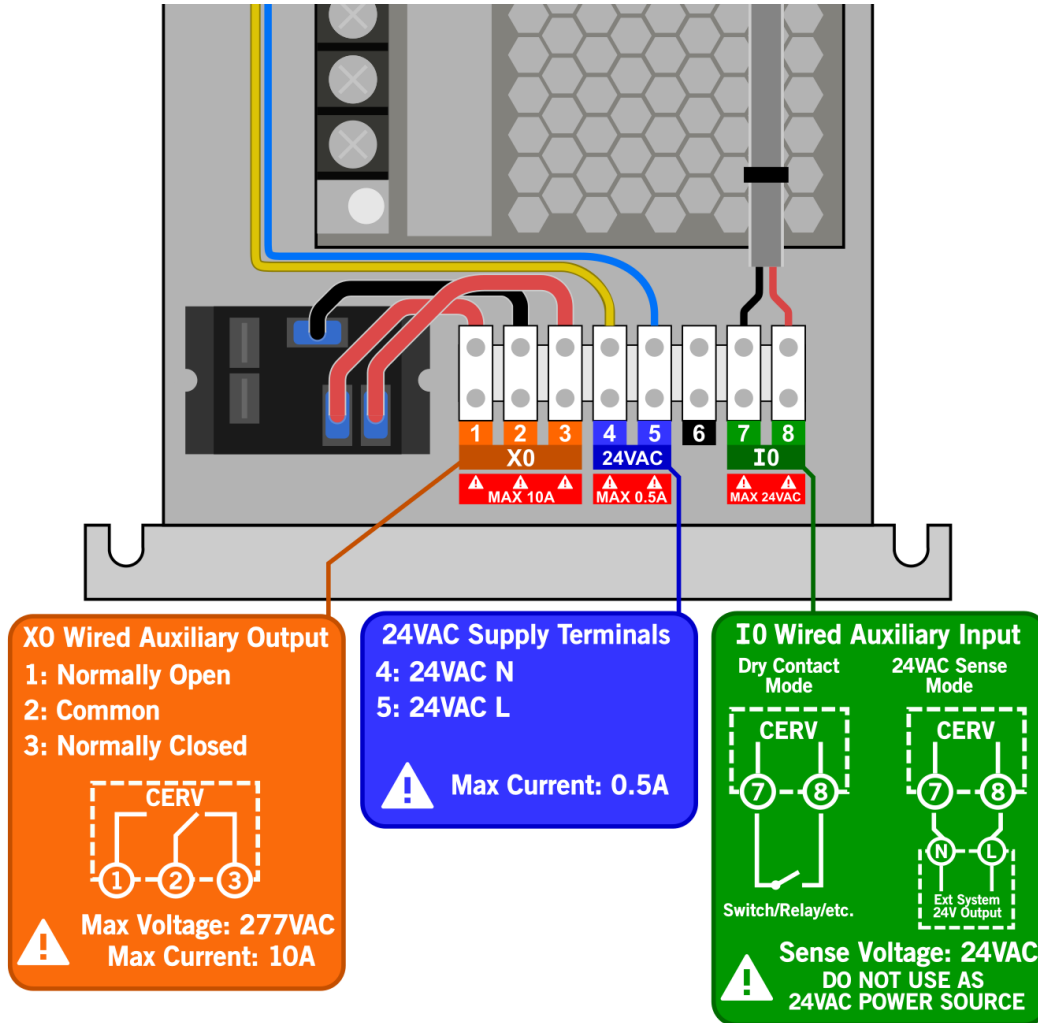

Main CERV Control Board

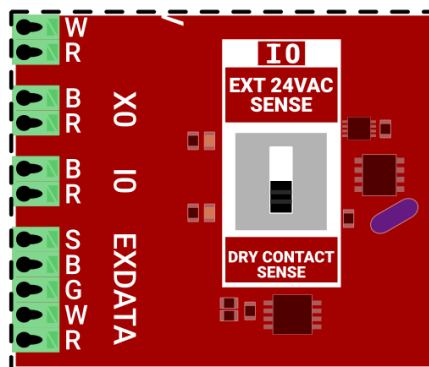

Note: To configure IO for External 24VAC Sense or Dry Contact Sense, the switch on the main CERV control board must be set accordingly.

Wired Auxiliary Output Example – Inline Duct Heater (wiring)

The CERV2 can control electric heaters in two ways; dry contact, where the heater is supplying a 24V signal, or 24V signal where the CERV is directly supplying the 24V control signal. Installation should only be performed by a trained professional. Turn power off to CERV2 and unplug or turn off breaker before performing any wiring. Incorrect wiring can damage components and void warranties. Please review your electric heater's installation instructions carefully to see which heater control applies. Schematics below show the wiring configurations for the two cases. In either case, low voltage control wire can be used such as standard 2 conductor thermostat wire.

For the dry contact connection, 24V from the heater is connected to terminal 2 on the CERV2's output channel. Terminal 1 is then wired back to the heater. When the CERV2 activates the heater the relay will close the connection between terminals 1 and 2 allowing the 24V signal to go back to the heater control to activate it.

For the 24VAC signal control connection, a jumper is needed between CERV2 terminals 2 and 4. Terminal 4 is a 24VAC output channel. The control wires from the heater then connect to terminals 1 and 5. To activate the heater the CERV will activate a relay to close the connection between terminals 1 and 2. This allows 24VAC to pass through to the heater's controls to activate heat.

After making the wiring connections, see next section to configure heater on CERV2 controller.

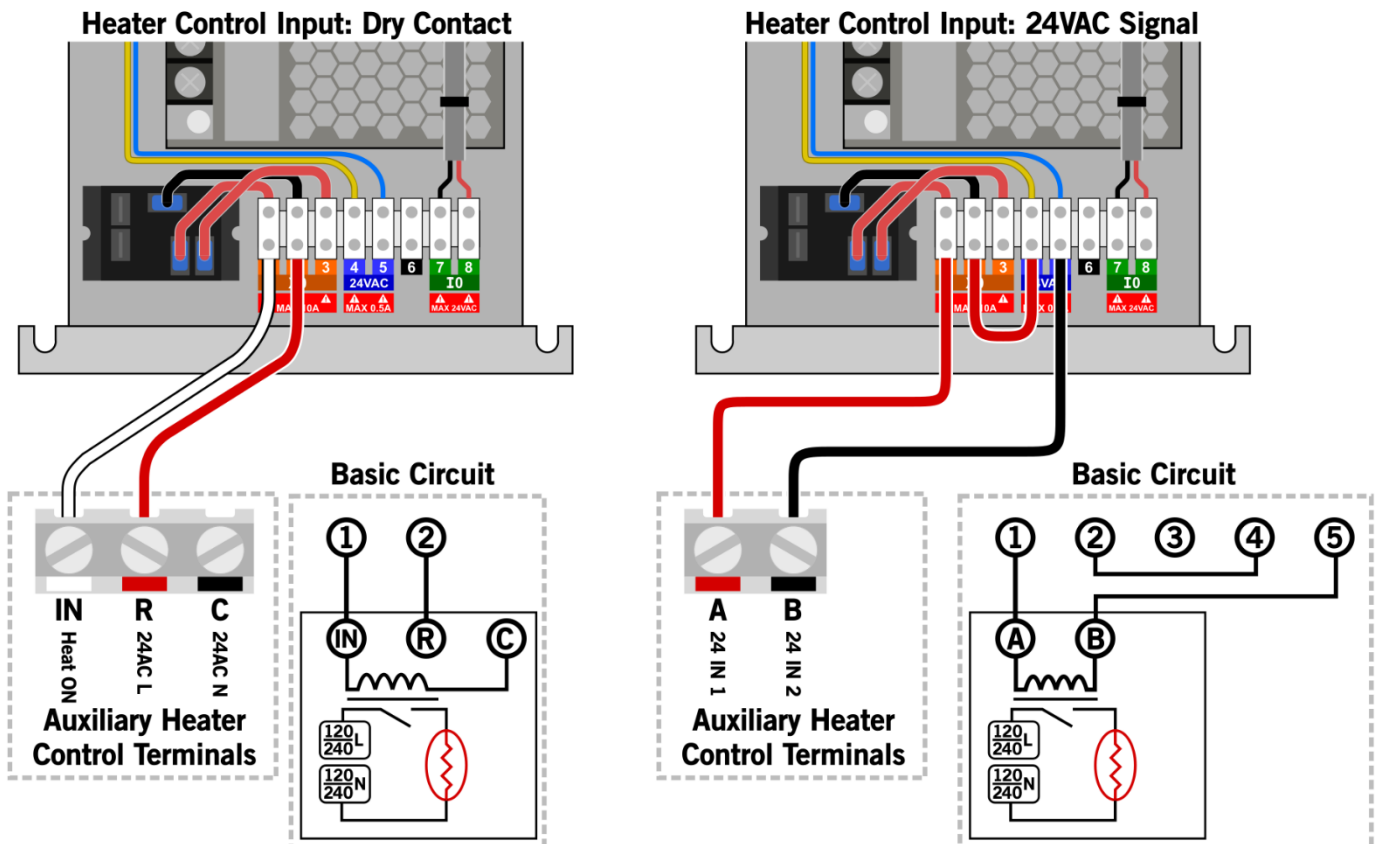

Wired Auxiliary Output Example – Inline Duct Heater (Configuration)

After completing the electric heater wiring, the CERV2 output channel must be configured through the controller. Follow the schematic below. When the external heater is on, a heater icon will appear in the status bar of the home screen located in the upper right corner.

Wired Auxiliary Output Setup

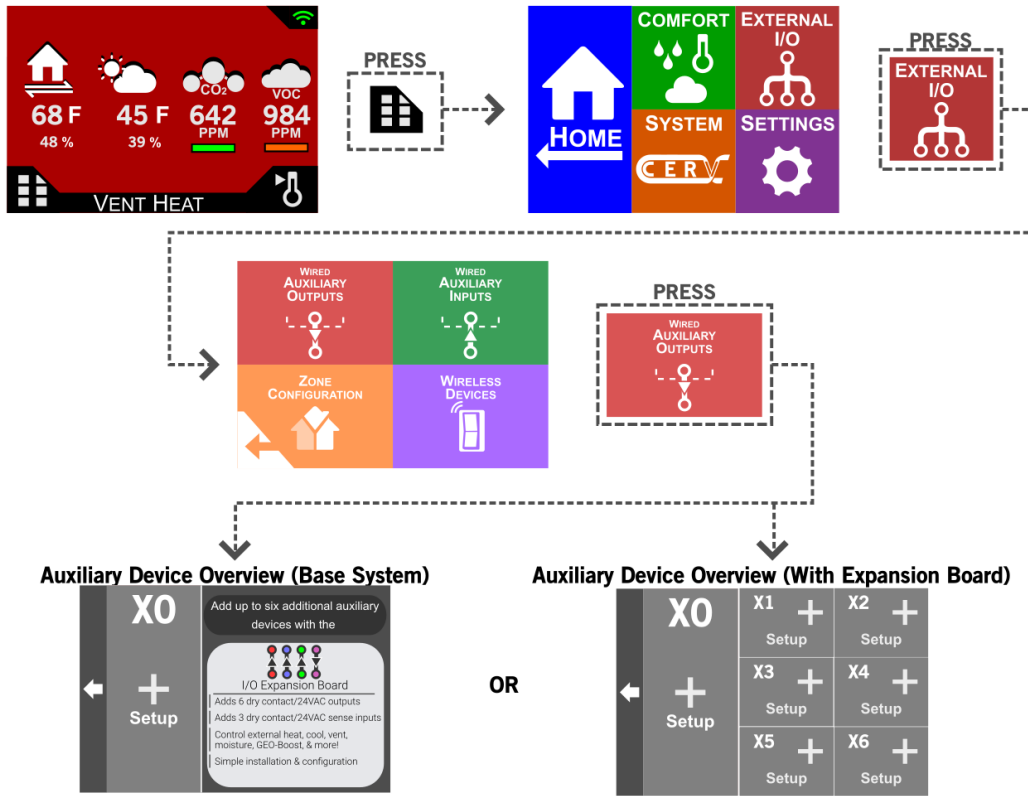

Configure Auxiliary Output

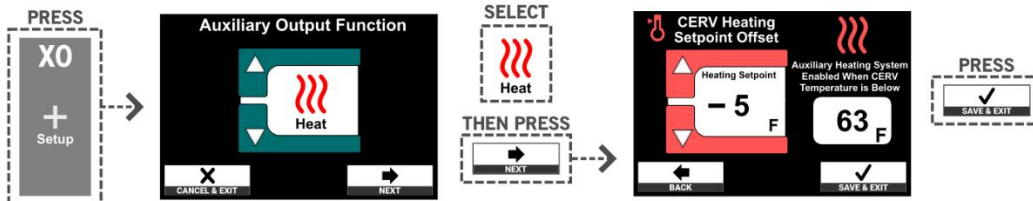

Auxiliary Device Overview Icons

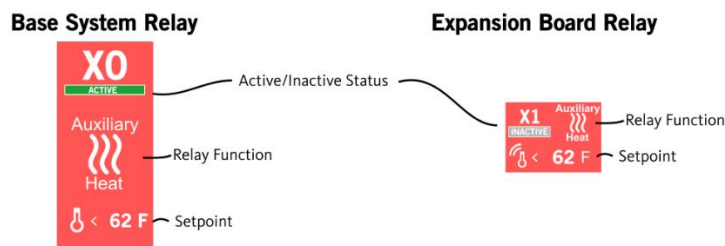

Wired Auxiliary Output Example – Fan Interlock (wiring)

Electrical Wiring

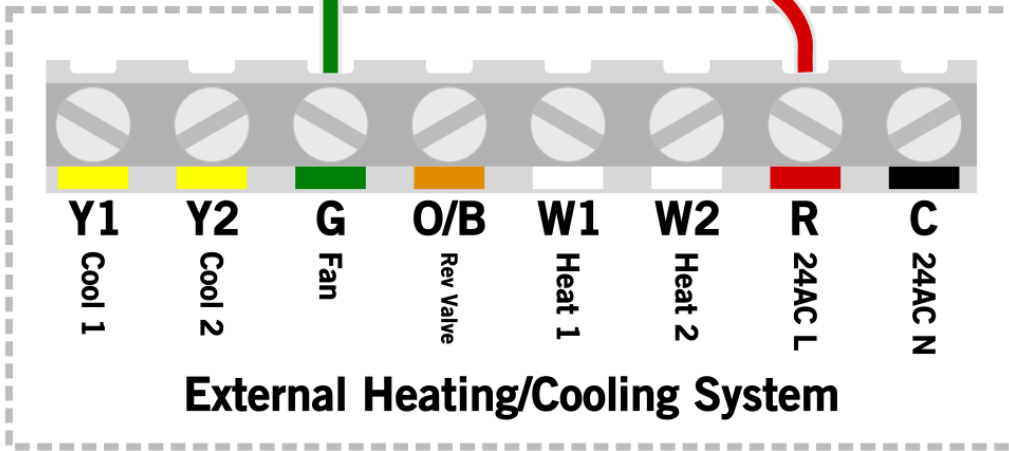
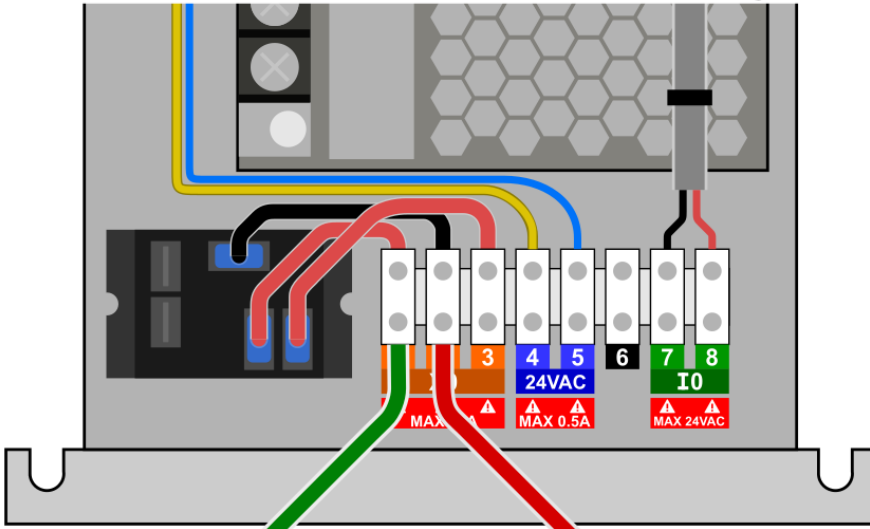

Basic Circuit

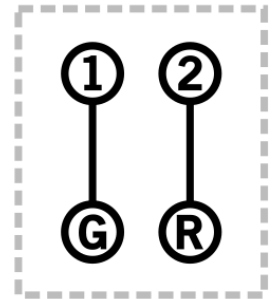

Wired Auxiliary Output Example – Fan Interlock (Configuration)

Wired Auxiliary Output Setup

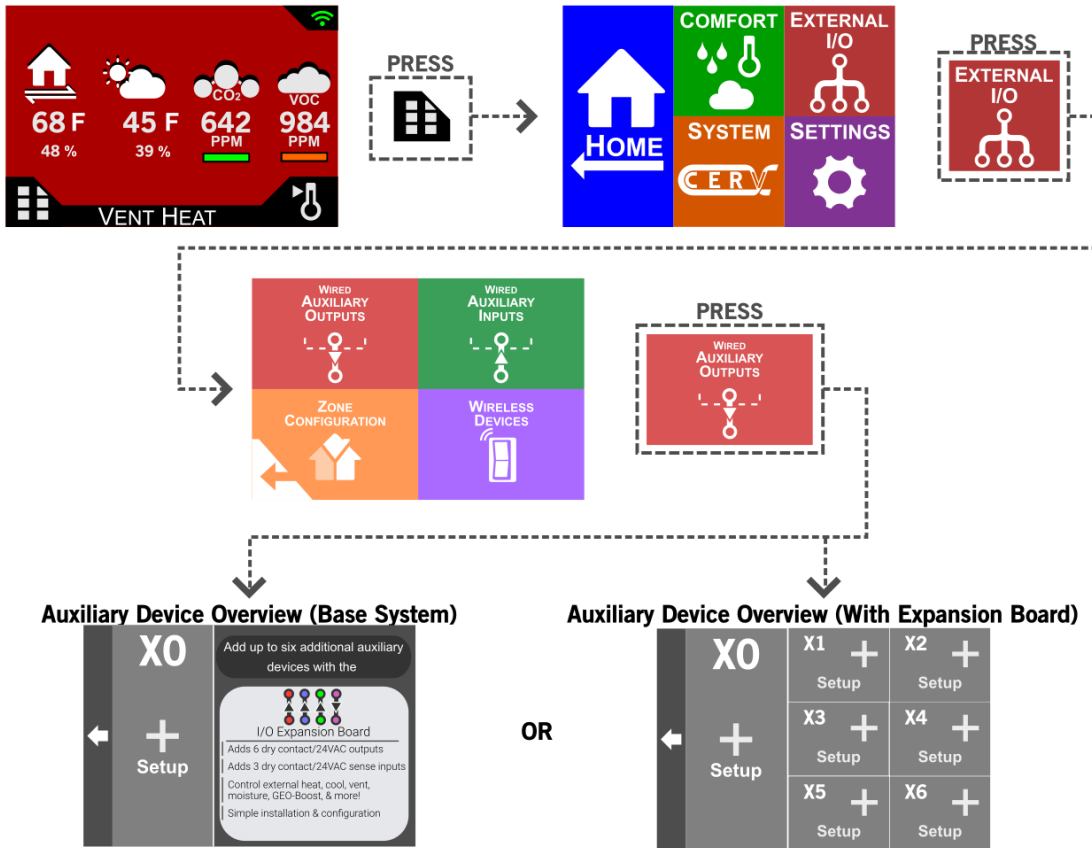

Configure Auxiliary Output

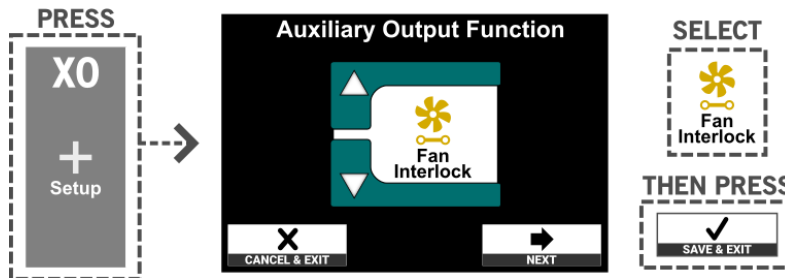

Fan Interlock Notes:

When an Auxiliary Output is configured with the Fan Interlock functionality, the CERV will enable the output relay, connecting the Normally Open and Common terminals internally. This will occur any time the CERV fans are operating. When the CERV goes into the Off operational mode, the output relay is disabled.



www.buildequinox.com

1103 N. High Cross Rd.
Urbana, IL 61802

support@buildequinox.com
(773)-492-1893