



1103 N HIGH CROSS RD
URBANA, IL 61802
1-773-492-1893

INSTALLATION MANUAL

GEO-BOOST GROUND LOOP HEAT EXCHANGER



REV 1.0

The Geo-Boost system consists of the Geo-Boost heat exchanger and a relay controller box. For geothermal circulation pump and loop (not included) detailed specifications and sizing, see the General Geo-Loop Information section at the end of this manual.

Recommended Pump and Loop Specifications

Geo-loop pipe: 3/4" to 1" diameter PEX tubing

Geo-loop length: 150' to 300'

Circulation flow: >1 gpm

Circulation fluid: 50/50 mix propylene glycol

Geo-Boost Heat Exchanger Specifications

Weight: 38 lbs

Duct connections: 6" diameter, airflow can be either direction

Geo-loop fluid connections: 1/2" copper stubs for Sharkbite or hose clamps

Condensate drain connection: 1/2" FNPT

Isometric



Side

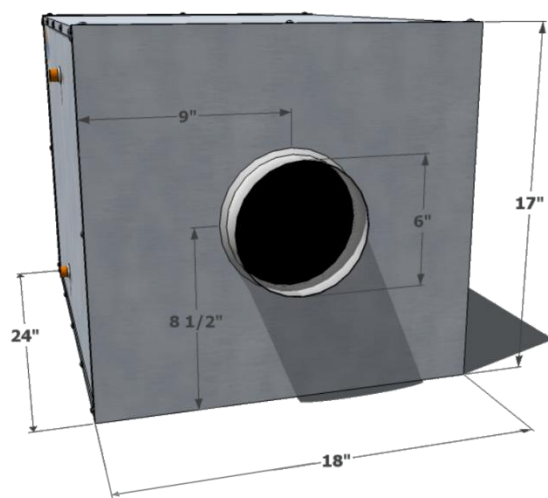

Front

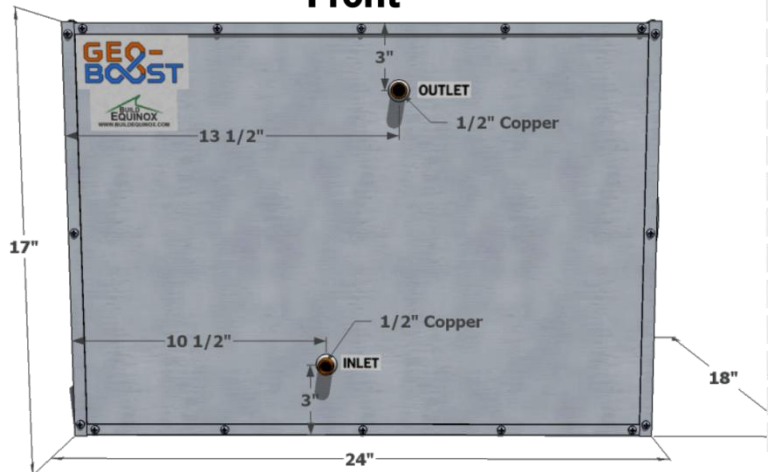

Bottom

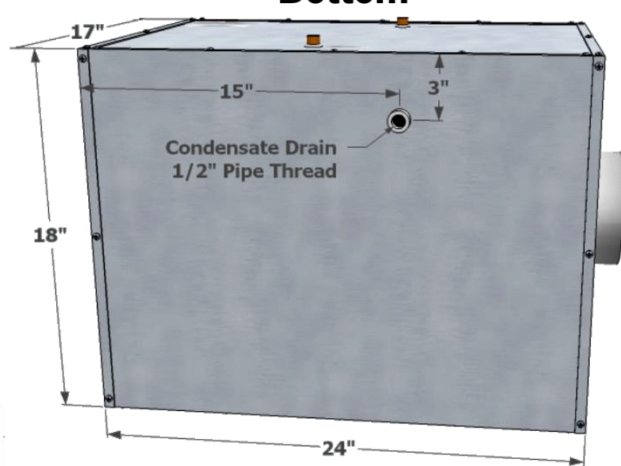

Geo-Boost Relay Controller Specifications

Max Switching Voltage: 300 VAC

Max Switching Current: 15 A

Recommended Switching Wire Size: 14 AWG

Recommended Control Wire Size: 20 AWG

Conduit Fitting Size: 3/4" Female PVC

Isometric

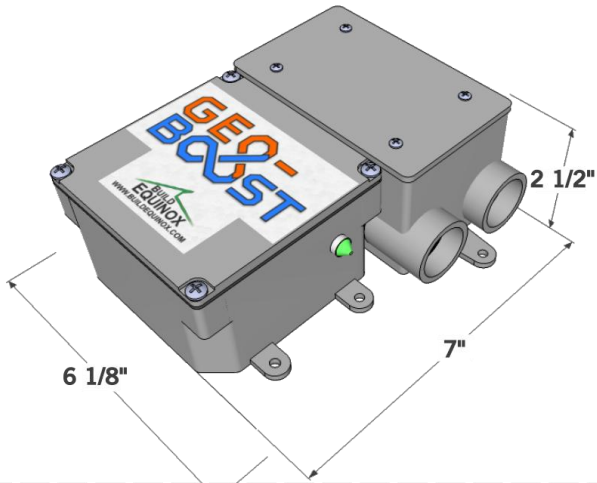

Side

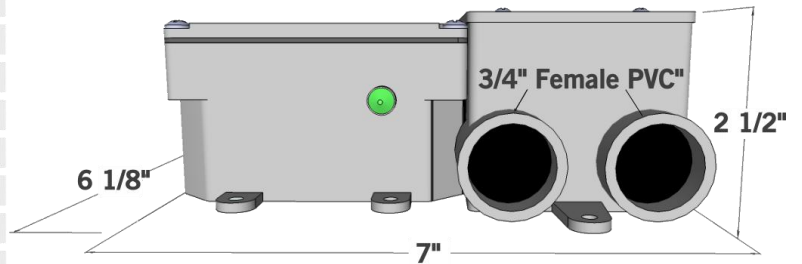

Front

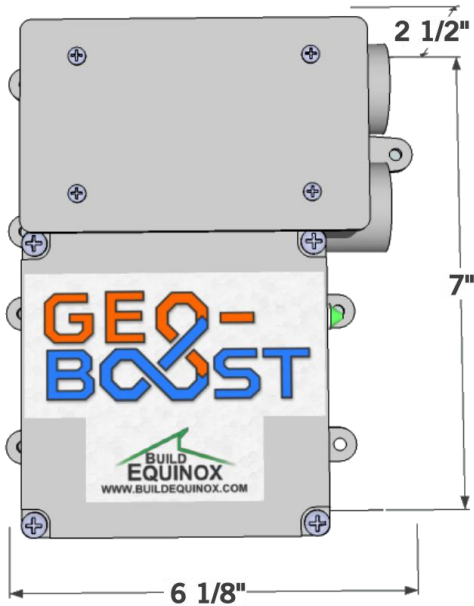

Mounting Hole Pattern

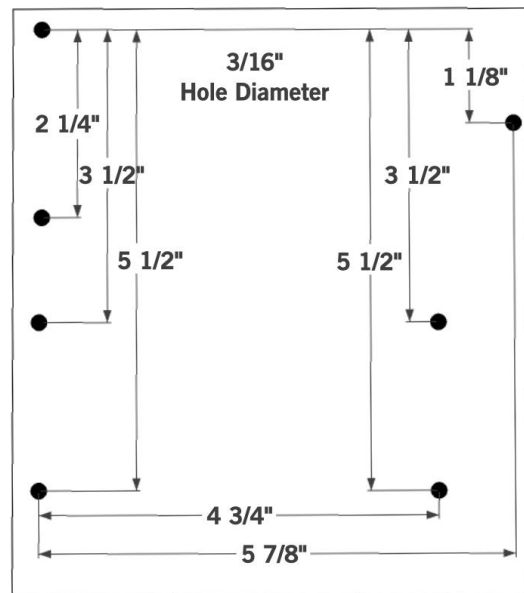

General Information

Geo-Boost converts the CERV into a hybrid geothermal-air source heat pump, increasing both heating and cooling capacities and efficiencies. The Geo-Boost unit is connected to a geothermal loop to make use of steady ground temperatures, which allows the incoming fresh air to be either pre-heated or cooled before going to the CERV. The Geo-Boost system consists of a high efficiency, high quality heat exchanger mounted in a thermally broken (no thermal bridging) insulated housing with condensate drain outlet, and a separate relay controller box that communicates with a CERV fresh air ventilation system. The relay controller, in conjunction with the CERV's temperature sensors, assesses Geo-Boost fresh air heating or cooling potential. Whenever Geo-Boost operation is determined to be favorable, the relay controller will activate the circulation pump (not included) to move fluid through the heat exchanger.

The Geo-Boost has 6 inch diameter duct fittings, and is placed in the fresh air intake duct between the in-line fresh air filter and the CERV. Half inch copper tube inlet and outlets connect to the geothermal loop. A ½" FNPT drain fitting from the condensate pan at the bottom of the heat exchange unit is connected to a drain line. A trap is required in the drain tubing in order to form a liquid seal. The drain tubing can either drain by gravity or to a condensate pump. The Geo-Boost heat exchanger unit requires no power wiring or control wiring, allowing it to be placed in the fresh air duct where most convenient. Power and low voltage wire are only required for the relay controller box, which can be mounted near the pump and/or CERV. The schematic below shows the Geo-Boost placement in the CERV's fresh air inlet and the wire connections for the relay controller. Refer to the General Geo-Loop Information section for geothermal loop layout and circulation pump selection.

Installation Schematic

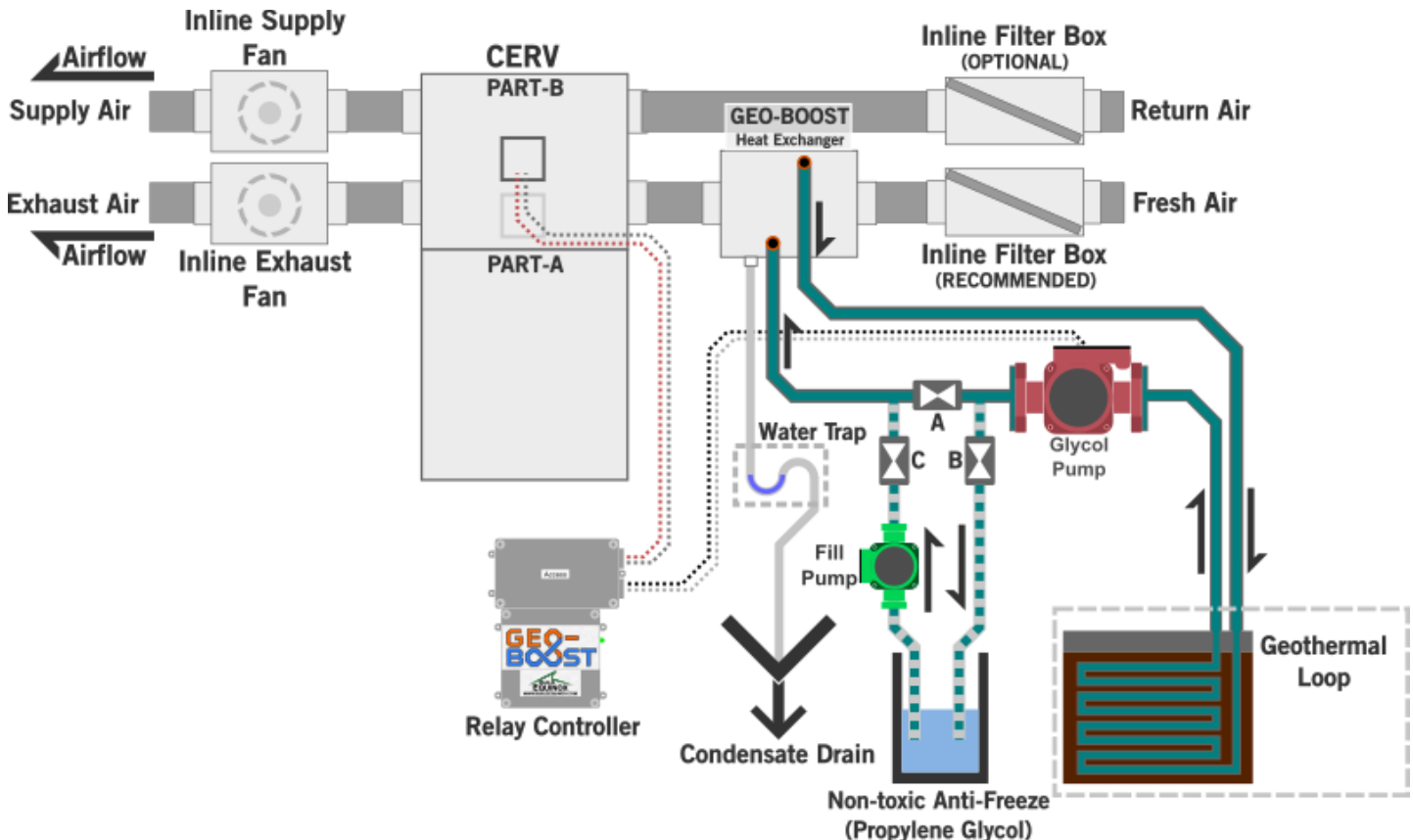

Installation Steps

It is very important to install the unit with the proper orientation (reference above installation schematic). Markings on the Geo-Boost show the liquid inlet and outlet. The unit's air flow can be in either direction. The following is a guide for proper installation:

- 1) Install the Geo-Boost heat exchanger in the fresh air duct between the fresh air filter and the CERV's fresh air inlet with 6 inch duct. It must be installed in a horizontal orientation only with the condensate drain outlet on the bottom. Be sure that the unit is level to allow for proper drainage of condensation. Allow enough clearance under unit to make condensate drain connection with a proper liquid trap. All fresh air inlet ducts must be well insulated, appropriate for the climate location. Any duct areas that become moist, wet or frosted in winter require additional insulation or better sealing.
- 2) Connect condensate tubing to the Geo-Boost drain fitting (1/2" FNPT). The drain tubing requires a trap as shown in the schematic. A barbed fitting with flexible tubing or rigid PVC tubing can be used. If flexible tubing is used a loose knot in the tubing can suffice as the trap. Be sure that there are no kinks in the hose. Note that condensate may form during summer cooling operation, but no condensate should appear during winter operation.
- 3) Make connections for the geothermal pipe loop including the fill pump and charging valves as shown in the schematic. Half inch "Sharkbite" type fittings or screw clamps can be used to connect to the Geo-Boost inlet and outlet 1/2" copper stubs. Do not sweat fit or braze copper tubing to the Geo-Boost inlet and outlet tubes. Charge the geo-loop system and check to make sure leak free. Refer to the General Geo-Loop Information section on charging the geo-loop.
- 4) Mount the Geo-Boost relay control box in a location that is convenient for running control wiring to the CERV and connecting the relay box to a 120VAC power supply and to the circulation pump.
- 5) Make electrical connections as detailed below in the Electrical Wiring section.
- 6) Once Geo-Boost is installed with geo-loop fully charged and purged of air and the electrical wiring complete, power can be restored to the CERV. The CERV will begin its initial assessment upon regaining power. Continue to the next section on enabling Geo-Boost, setup and operation.

Electrical Wiring

 ***Danger: risk of electric shock that can cause injury or death. Proper precautions should be used when making electrical connections. Be sure that power is off to relevant circuits while installing or servicing.***

The Geo-Boost relay controller gives the CERV the ability to intelligently control the Geo-Boost through the CERV's Auxiliary Output channel. 120 VAC power is run to the relay controller and then from the relay controller to the geo-loop circulation pump. Low voltage signal wire is connected between the relay controller and the CERV.

The relay controller box consists of two enclosures. The lower enclosure with Geo-Boost and Build Equinox labels contains the relay and electronics (and should be left sealed), while the other enclosure provides access for making the glycol pump's wired connections. The access box is a standard single gang PVC conduit box, compatible with standard 120VAC electrical outlets or GFCI outlets. Two 3/4"

female PVC conduit connections are available for running wires outside the box. These can be used with a variety of conduit fittings, allowing the use of rigid conduit, or non-metallic strain relief fittings. Tabs with holes around the perimeter of the box should be used for mounting the box on a smooth, vertical surface. Box mounting orientation does not matter. A green LED located on the side of the box indicates when the circulation pump is on.

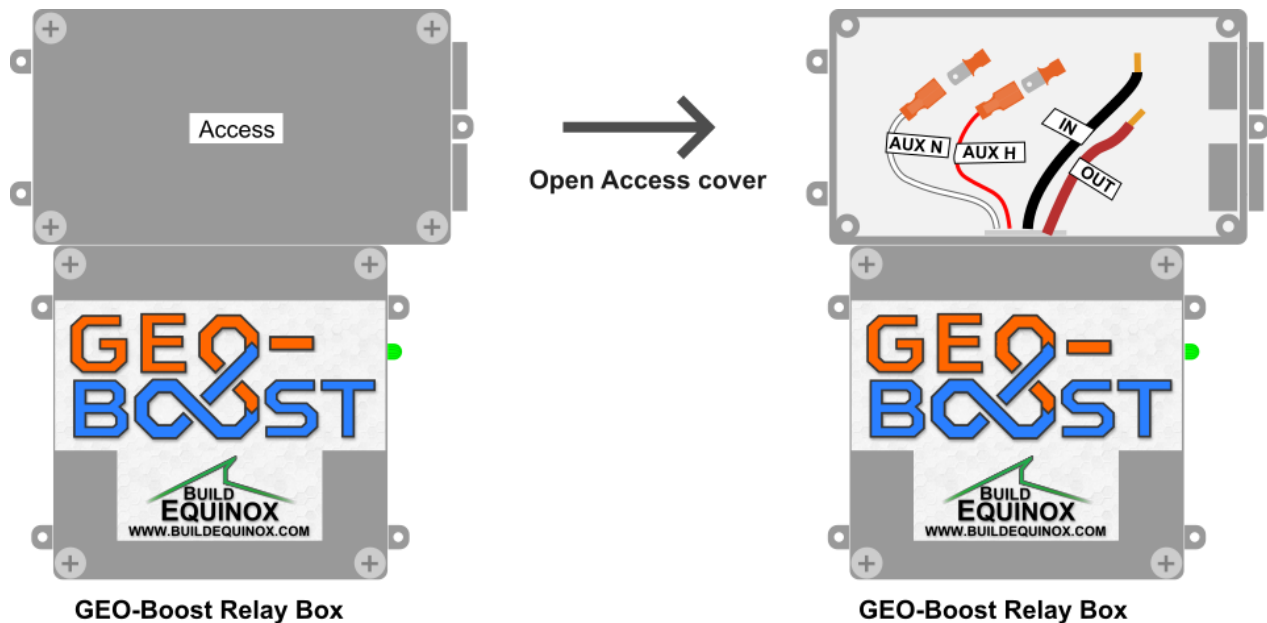

1. Before beginning, turn off power to the CERV.
2. Remove the access panel of the relay controller box (as seen in the figure above). There are four wires: AUX H, AUX N, IN and OUT. The AUX H and AUX N wires are terminated with 0.187 in x 0.02 in fully insulated female quick connect terminals. The male quick connect terminals are included for your convenience, and can be crimped on to low voltage wiring (such as 2-conductor thermostat wire).
3. Using low voltage wire connect the AUX N and AUX H wires to terminals N and H on the bottom terminal block of the CERV's low voltage junction box as shown in the figure below. This control wire activates the relay that switches on and off power to the circulation pump.
4. For the power wiring, use a wire size appropriate for the pump power. There are two ways to wire power to the circulation pump.
 - a. For the standard installation as shown in the figure below, wires can be connected using wire nuts. 120 VAC neutral and ground are connected directly to the circulation pump, while the hot wire is connected to the black IN wire. Another wire is connected to the red OUT wire with a wire nut and run to the line voltage leg on the pump. This completes the wiring for standard installation and the access cover can be screwed back on. Continue to the next step of the installation instructions.
 - b. Alternatively, a 120V outlet (regular or GFCI) may be installed in the relay box in place of the access cover. 120 VAC neutral and ground should be connected directly to the outlet. The hot wire is connected to the IN wire and then another wire is connected from the OUT

wire to the line voltage terminal on the outlet. A standard 120V plug should be wired to the circulation pump, which simply plugs into the outlet on the relay controller box.

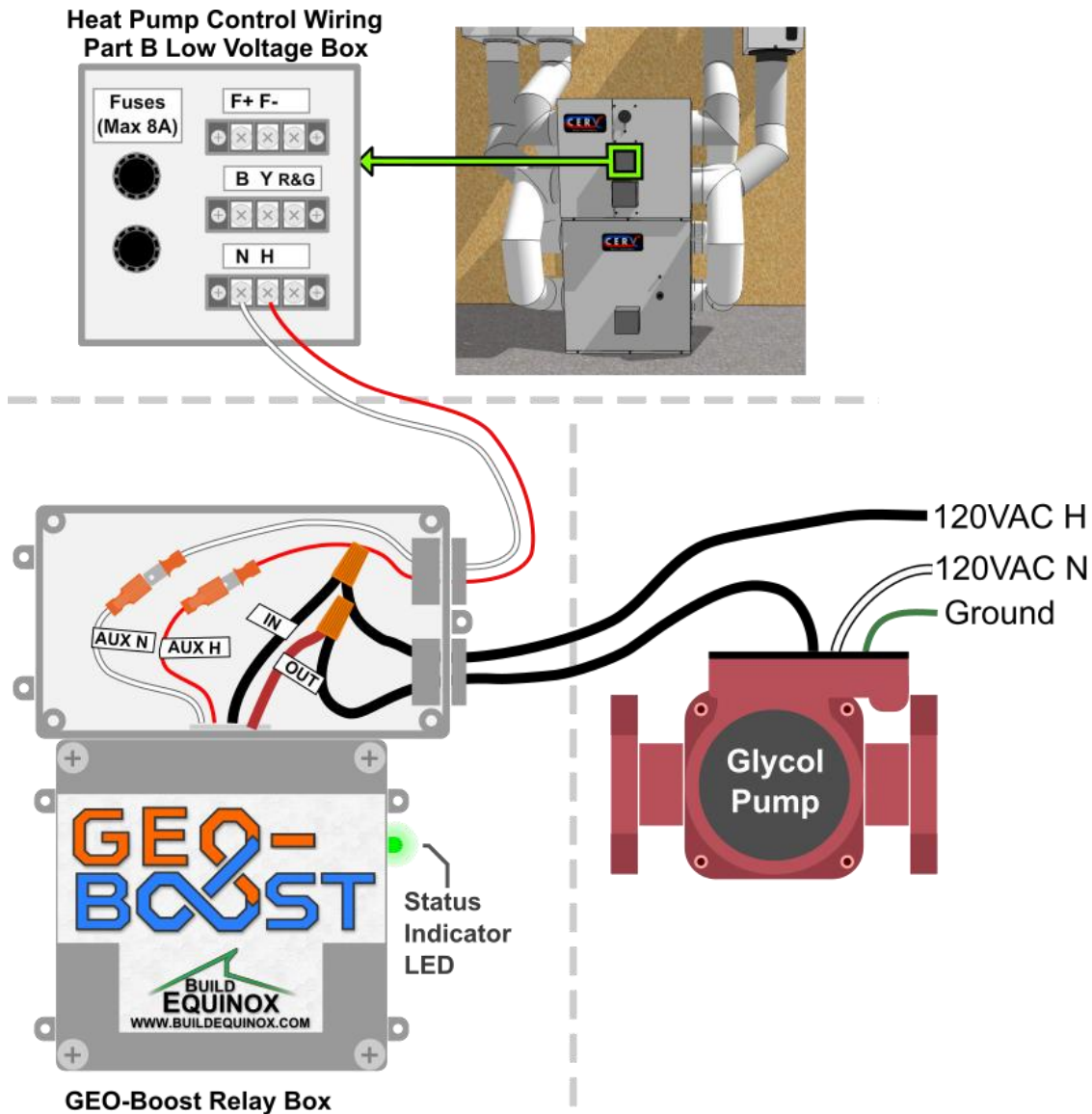

Geo-Boost Setup and Operation

Setup

Enable the Geo-Boost option on the CERV touch screen controller as shown below. The option is located in the Auxiliary Device selector. Scroll through the devices to find Geo-Boost, and press the check mark button to enable. With the Geo-Boost option enabled and the CERV completing its assessment, the Geo-Boost should activate the circulation pump for its own assessment if the CERV changes to a heating or cooling mode. The green LED on the relay controller box will be lit if the circulation pump is running. If the CERV is within set points after its assessment and is not heating or cooling, temporarily change one of the heating or cooling set points so that the CERV will begin to heat or cool. This should then start the Geo-Boost assessment to see that the pump is activating properly.

The temperature set point can be changed back after verifying that the pump works. After verifying that the pump is operating correctly, set up is complete.

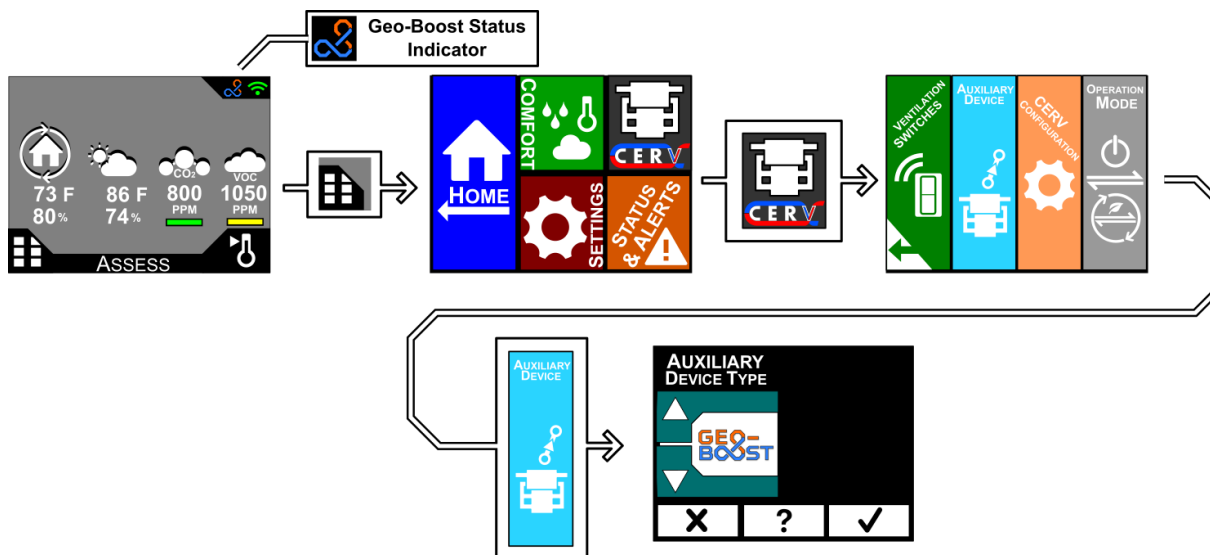

Operation

The CERV is able to intelligently determine when the Geo-Boost provides beneficial heating or cooling to the system through the use of its internal sensors and algorithms. Through periodic assessments the CERV determines when using the Geo-Boost is beneficial or not. A Geo-Boost assessment consists of running the geothermal circulation pump at different times to determine the net effect. This is all done automatically, so there are no user inputs needed once Geo-Boost has been enabled.

The CERV's mode of operation, inside and outside ambient temperatures, and ground temperature all impact whether Geo-Boost is beneficial or not. Changes in ground temperature throughout the year also have an impact on the system. There are certain conditions where assessments are not needed, so the CERV may go long periods of time without doing a Geo-Boost assessment. Geo-Boost is most likely to be beneficial during more extreme cold and warm weather periods. The Spring and Fall swing seasons will not see much of a benefit, therefore the Geo-Boost will most likely remain off. Note that because Geo-Boost pre-conditions the air to the CERV when it is being used this further offsets the air inlet temperature to the CERV from the outside ambient temperature, which is displayed on the home screen of the CERV controller.

General Geo-Loop Information

Geo-Loop Circulation Pumps and Pipe Loops:

Circulation pumps for geo-loops are similar to those used for other hydronic systems such as solar collector fluid circulation and radiant floor heating. Grundfos UPS15-58F/FC, Grundfos Alpha, Taco OOR 3 speed pump, or similar pumps are recommended for Geo-Boost pipe loop circulation. These pumps require less than 80 Watts and will maintain a recommended flow of 1 gpm or greater. With outdoor temperatures of 0F, the Geo-Boost will add 500 to 700Watts of heating capacity to the ambient air based on geo-loop fluid delivery temperatures of 35 to 55F to the Geo-Boost heat exchanger.

Installing the pump before the Geo-Boost adds part of the pump's power to the geo-loop fluid, resulting in the pump's energy transferred as heat into your home.

Pipe loops should use 3/4" or 1" diameter plastic piping. Oxygen barriers are not needed in the plastic piping. "Black plastic" or PEX type plastic tubing with pipe loop lengths in the 150' to 300' range are suitable. Well-drained sandy soil requires longer tube lengths due to lower ground thermal conductivity and thermal energy capacitance while wetter soils can use shorter tube lengths. The deeper the better for burying tube to reach deep earth temperatures.

The four tables below show the flow and pressure (called "head") characteristics for 3/4" and 1" diameter geo-pipe loops that are 150ft and 300ft in length. The piping pressure drop is proportional to the geo-pipe length, which allows the tables to be used for other pipe length calculations. For example, the difference between 150ft and 300ft of 3/4" pipe with 1 gpm of flow is ~0.9' H₂O head (13.59'-12.72'). That is, for each 150' of 3/4" pipe at 1gpm flow 0.9' head is added. A 450' pipe loop would add 0.9'H₂O plus 13.6'H₂O (pressure drop for 300' of 3/4" pipe plus Geo-Boost heat exchanger) for a total of 14.5'H₂O pressure drop. Most of the pressure drop occurs in the heat exchanger, so adding additional pipe length does not significantly increase pressure drop, however, pipe diameters below 3/4" rapidly increase overall system pressure drop. If smaller diameter pipe loops are desired, two or more loops could be connected in parallel. Calculated pressure drops can be used with the pumps flow curve to find the resultant flow rate. Overall, the pump and loop sizing should result in a flow rate of ~1gpm or more.

Geo-loop piping flow and pressure characteristics

3/4" & 150' Ground Loop and Heat Exchanger			3/4" & 300' Ground Loop and Heat Exchanger		
Flow (gpm)	Head ('H ₂ O)		Flow (gpm)	Head ('H ₂ O)	
0.5	3.79		0.5	4.05	
1	12.72		1	13.59	
1.5	25.83		1.5	27.60	

1" & 150' Ground Loop and Heat Exchanger			1" & 300' Ground Loop and Heat Exchanger		
Flow (gpm)	Head ('H ₂ O)		Flow (gpm)	Head ('H ₂ O)	
0.5	3.60		0.5	3.67	
1	12.08		1	12.30	
1.5	24.52		1.5	24.97	

The amount of anti-freeze solution for charging the system depends on the length and diameter of the ground loop. Non-toxic propylene glycol is recommended for anti-freeze protection. The adjacent table provides estimates of anti-freeze volume for 3/4" to 1" pipe with 150ft to 300ft ground loop piping lengths. A 50/50 mix by volume of propylene glycol and water is recommended, premixed is fine.

Pipe ID	Loop Length	LoopVol Volume
inch	ft	gal
0.75	150	3.7
0.75	300	7.2
1	150	6.4
1	300	12.5

Geo-loop anti-freeze charging:

Adding fluid (anti-freeze and water mixture) to a geo-loop requires a charge pump that has sufficient pressure and flow capability to move air out of the loop, and to pressurize the loop slightly (~5-10 psi) above atmospheric pressure. Maintaining a loop pressure higher than atmospheric pressure keeps air from being drawn into the loop. Air in the loop can block flow, create noise, and corrode metal components in the ground loop.

The ground loop piping schematic shows three valves (Valves A, B, and C) that are used to charge fluid into the loop. Valve A can be either a check valve or a ball valve (preferred) that prevents reversed flow during loop charging. Valves B and C can be "hose bib" valves that have garden hose fittings on one end of the valve.

The charge pump should be a self-priming transfer pump with "hose bib" fittings such as a Simer or Wayne pump found in most big box and hardware stores. Relatively short length hoses, such as laundry hoses, can be connected to the pump's inlet and outlet fittings. The hose on the pump's outlet is connected to Valve C. The pump inlet hose should be placed in the bottom of a container holding the anti-freeze solution (eg, 5 gallon bucket). It is important that the pump inlet hose is held at the bottom of the container such that air bubbles cannot be drawn into the loop. The inlet hose to the pump should have sufficient wall thickness and stiffness to prevent hose collapse as the pump draws fluid from the fluid charge holding container.

A third hose is connected to Valve B that returns anti-freeze to the container as the loop charge pump circulates fluid through the loop. The return hose should also be kept below the surface of the anti-freeze container in order to observe when bubbles are no longer entering the container, and to keep the returning fluid from entraining air into the bucket. During the circulation process, Valve A can be opened and closed periodically which helps jar air bubbles from various locations in the loop. Note that a 1 gpm (gallon per minute) loop circulation rate requires ~10 to 15 minutes to travel through a 1" diameter, 300 ft long pipe loop.

When bubbles are no longer observed returning to the container, Valve B can be slowly closed, building up pressure in the loop. Once Valve B is fully closed, Valve C can be closed and the charge pump immediately turned off. Note that the charge pump should be operating while Valve B and Valve C are closed, but that the pump should be turned off immediately after Valve C is closed.

The ground loop schematic does not contain an "expansion" tank because the plastic tubing used for the ground loop has sufficient flexibility to act as its own expansion tank. In "hard pipe" systems, such as hydronic heating loops with copper pipe or "closed loop" solar hot water collector circulation systems, expansion tanks are needed in order to keep pressure variations small as water expands and contracts with temperature changes. A long plastic pipe run in a ground loop inherently has sufficient flexibility that minimizes the need for an expansion tank.